

Test Report

Report No.: KEYS241203038001LD-01

Date: Dec. 18, 2024

Page 1 of 31

TEST REPORT EN 15194 Cycles - Electrically power assisted cycles - EPAC Bicycles	
Report Number..... :	KEYS241203038001LD-01
Total number of pages.....	31 pages
Tested by (name + signature)..... :	Echo Zhong <i>Echo Zhong</i>
Approved by (name + signature)....:	Jason Zhan <i>Jason Zhan</i>
Testing Laboratory Name..... :	Guangdong KEYS Testing Technology Co., Ltd.
Address..... :	Building 1, No.18, Shihuan Road, Dongcheng Subdistrict, Dongguan, Guangdong, China
Applicant's name..... :	Yancheng Kuailun intelligent Technology Co.,Ltd
Address..... :	No,1 , Intelligent Terminal Industrial Park, East Yinhai Road, South Guanjiang Road,Xiangshui Economic Development Zone, Yancheng City, Jiangsu Province
Manufacturer's name..... :	Yancheng Kuailun intelligent Technology Co.,Ltd
Address..... :	No,1 , Intelligent Terminal Industrial Park, East Yinhai Road, South Guanjiang Road,Xiangshui Economic Development Zone, Yancheng City, Jiangsu Province
Test specification:	
Standard..... :	EN 15194:2017AMD.1:2023
Test procedure..... :	Safety report
Non-standard test method..... :	N/A
Test item description..... :	Ebike
Trade Mark..... :	N/A
Model/Type reference..... :	K1, K1 pro
Ratings..... :	DC 54.6V/3A charging from adapter DC 48V /20Ah/960Wh by battery



Scan to view the original file

Guangdong KEYS Testing Technology Co., Ltd.

Address: Building 1, No.18, Shihuan Road, Dongcheng Subdistrict, Dongguan, Guangdong, China
Tel: +86-0769-89798319 <http://www.keys-lab.com> E-mail: info@keys-lab.com

This report is only responsible for the test results of the samples submitted for inspection, and is not responsible for the source of the samples submitted for inspection. This report shall not be altered, increased or deleted. Without written approval of KEYS, this test report shall not be copied except in full and published as advertisement.

Test Report

Report No.: KEYS241203038001LD-01

Date: Dec. 18, 2024

Page 2 of 31

General disclaimer:

This report is only for applicant use. Any copying this report to/for any other person or entity, and use our name or trademark, is permitted only with our prior written permission. This report sets forth our findings solely with respect to the test samples identified herein. The results set forth in this report are not indicative or representative of the quality or characteristics of the lot from which a test sample was taken or any similar or identical product unless specifically and expressly noted. Our report includes all of the tests requested by you and the results thereof based upon the information that you provided to us. Unless specific mention, the uncertainty of measurement has been explicitly taken into account to declare the compliance or non-compliance to the specification

List of Attachments:

Attachment 1: 1 pages of photos.

Summary of testing:

The tested samples fulfilled the requirements of specified standards.

Testing location:

Guangdong KEYS Testing Technology Co., Ltd.

Building 1, No.18, Shihuan Road, Dongcheng Subdistrict, Dongguan, Guangdong, China

Summary of compliance with National Differences:

List of countries addressed:

The product fulfils the requirements of EN 15194:2017AMD.1:2023

Remark:

/

Test Report

Report No.: KEYS241203038001LD-01

Date: Dec. 18, 2024

Page 3 of 31

Copy of marking plate:

The artwork below may be only a draft.

Ebike

Model No: K1

Max Load:120kg

DC 54.6V/3A charging from adapter

DC 48V/ 20Ah/960Wh by battery

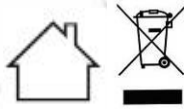

Manufacturer: Yancheng Kuailun intelligent Technology Co.,Ltd

**Address : No,1 , Intelligent Terminal Industrial Park, East Yin Hai Road,
South Guanjiang Road,Xiangshui Economic Development Zone,
Yancheng City, Jiangsu Province Made In China**

Importer: xxx

Address: yyy

Note:

1. xxx means importer company name; yyy means importer company address information.
2. The marking for the other models are identical as above except the model no. only.
3. As declared by client that the name (or registered trade mark) and address of the certificate holder (manufacturer) or the importer or authorized representative based within the European Economic Area will be clearly affixed on the product or where that is not possible, on the packaging or in a document accompanying the product.
4. The height of letters and numerals was not less than 2mm.
5. The height of symbol “” was not less than 7mm.
6. The height of the other graphical symbols was not less than 5mm.

Test Report

Report No.: KEYS241203038001LD-01

Date: Dec. 18, 2024

Page 4 of 31

Test item particulars.....	See test report
Classification of installation and use.....	Class III
Supply Connection.....	Use with adapters
Possible test case verdicts:	
- test case does not apply to the test object.....	: N/A
- test object does meet the requirement.....	: P (Pass)
- test object does not meet the requirement.....	: F (Fail)
Testing.....	
Date of receipt of test item.....	Dec. 3, 2024
Date (s) of performance of tests.....	Dec. 4, 2024 to Dec. 18, 2024
General remarks:	
"(See Enclosure #)" refers to additional information appended to the report.	
"(See appended table)" refers to a table appended to the report.	
Throughout this report a <input type="checkbox"/> comma / <input checked="" type="checkbox"/> point is used as the decimal separator.	
Name and address of factory (ies).....	Same as manufacturer
General product inform Ration:	
1. This product is Ebike, Class III with battery and class II adaptor (Model: FY1695463000. Input voltage: 100-240VAC Output: 54.6 3A 163.8W. Factory : SHENZHEN FUYUANDIAN POWER CO.,LTD).	
2. The model "K1" is selected as representative model for full tests are carried out on it.	
3. Sample Description: Ebike - For Adult. An electric assisted bicycle for riding	
4. Models Difference	
All series models are identical, except for model name difference for trading purpose.	

Test Report

Report No.: KEYS241203038001LD-01

Date: Dec. 18, 2024

Page 5 of 31

EN 15194			
Clause(s)	Test(s)	Test Remarks	Result
4	Safety requirements and/or protective measures		P
4.2	Electrical requirements		P
4.2.1	Electric circuit		P
	The electrical control system shall be designed so that, should it malfunction in a hazardous manner, it shall switch off power to the electric motor without causing a hazardous situation and it requires user interaction to switch on again..		P
4.2.2	Controls and symbols		On, off P
4.2.3	Batteries		P
	Battery terminals are short-circuited with the batteries in a fully charged condition. Motor terminals are short-circuited; all commands are in "ON" position, while the batteries are fully charged. The EPAC is operated with the electric motor or drive system blocked until the motor torque stops or the battery is fully discharged. The battery is charged for double the recommended charging period or for 24 h whichever is greater.		Charge 24h, The battery pass by EN 62133 P
4,2,4	Battery charger		P
	Chargers for EPAC are considered to be operated in a residential (household) environment.		Output:54.6V< 64.8V Pass by CE certificate P
4.2.5	Electric cables and connections		P
	All connectors for cable and wire shall be selected to prevent corrosion of electrical contact conductance.		P
4.2.5.3	At an ambient room temperature (20 ± 5) °C, discharge the fully charged EPAC battery to the discharging limit specified by the EPAC or ESA manufacturer at the maximum current allowable by the system and record it. Measure the cable and plug temperatures and ensure, by examination,		N/A

Test Report

Report No.: KEYS241203038001LD-01

Date: Dec. 18, 2024

Page 6 of 31

EN 15194			
Clause(s)	Test(s)	Test Remarks	Result
	that there is no deterioration of the insulation on either assembly.		
4.2.6	Wiring	No sharp edges on wire way. Cannot touch moving part	P
4.2.7	Power cables and conduits		P
4.2.8	External and internal electrical connections		P
4.2.9	Moisture resistance	>IPX4	P
4.2.10	Mechanical strength test		P
	Impact energy of 0.7J.	Three times, 0.7J, No damaged	P
	Detachable batteries are submitted to free fall on a rigid surface. 0.9m Three times		N/A
4.2.11	Maximum speed for which the electric motor gives assistance	25km/h	P
4.2.12	Start-up assistance mode		P
	An EPAC can be equipped with a start-up assistance mode that operates up to a maximum speed of 6 km/h. This mode shall be activated by the voluntary and maintained action of the user either when riding without pedalling or when the user is pushing the cycle.		P
4.2.13	Power management		P
	Assistance shall be cut off when the cyclist stops pedalling forward and the cut-off distance shall not exceed 2 m		N/A
	All braking devices (e.g. levers, back pedal) are equipped with cut-off switches, the cut off distance shall not exceed 5 m		P
	The power output or assistance shall be progressively reduced and finally cut off		P
	The assistance shall be progressively and smoothly		P

Test Report

Report No.: KEYS241203038001LD-01

Date: Dec. 18, 2024

Page 7 of 31

EN 15194			
Clause(s)	Test(s)	Test Remarks	Result
	managed		
	Two independent applying actions shall be required to start the electrical assistance mode		P
4.2.14	Maximum power measurement		P
4.2.15	Electro Magnetic Compatibility		P
4.2.15.1	Emission		P
4.2.15.2	Immunity		P
4.2.5.13	Battery charger		P
4.2.16	Failure mode		P
	It shall be possible to ride the EPAC by pedalling even if the assistance failed.		P
4.2.17	Anti-tampering measure	Sealing	P
4.3	Mechanical requirements		P
4.3.1.5	Fatigue test	Not to exceed 10 Hz, 1 000 test cycles	P
4.3.1.6	Fatigue test for composite components	2000 cycles	P
4.3.1.7	Plastic material test ambient temperature		P
4.3.1.8	Crack detection methods	No crack	P
4.3.2	Sharp edges	No sharp edge	P
4.3.3	Security and strength of safety-related fasteners		P
4.3.3.1	Security of screws	Lock-washers, lock-nuts	P
4.3.3.2	Minimum failure torque		P
4.3.3.3	Folding bicycles mechanism	Folded no damage the cables, No touch the wheel and unintentionally loosen or unlock	P
4.3.4	Protrusions	the rider is protected	P
4.3.5	Brakes		P
4.3.5.1	Braking-systems		P
4.3.5.2.1	Brake-lever position		P
4.3.5.2.1.1	Brake-lever grip dimensions		P
	The dimension, d, measured between the outer surfaces of the brake-lever in the region intended	>40mm	P

Test Report

Report No.: KEYS241203038001LD-01

Date: Dec. 18, 2024

Page 8 of 31

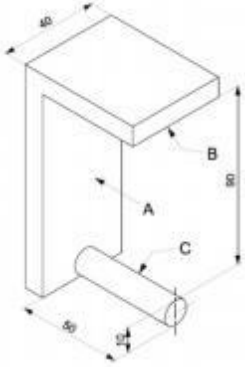
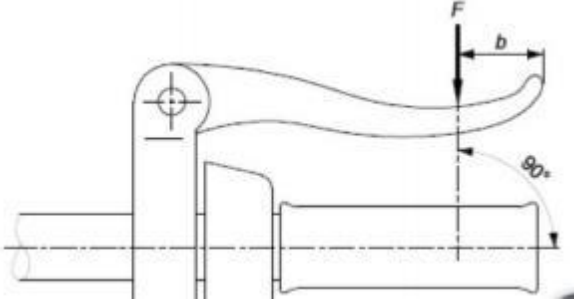
EN 15194			
Clause(s)	Test(s)	Test Remarks	Result
	for contact with the rider's fingers and the handlebar		
4.3.5.2.2.2	Test method for the brake-lever similar		P
			P
4.3.5.3	Attachment of brake assembly and cable requirements	<15N	P
4.3.5.4	Brake-levers – Position of applied force.	<10N	P
4.3.5.5	Brake-block and brake-pad assemblies – Safety test		P
4.3.5.5.1	The friction material shall be securely attached to the holder, backing-plate, or shoe and there shall be no failure of the braking system or any component thereof		P
4.3.5.6	Brake adjustment		P
	Each brake shall be equipped with an adjustment mechanism either manual or automatic.	Automatic	P
4.3.5.7	Hand-operated braking-system – Strength test	450N,10 cycle, No damage	P
			P
4.3.5.8	Back-pedal braking system – Strength test		N/A

Test Report

Report No.: KEYS241203038001LD-01

Date: Dec. 18, 2024

Page 9 of 31

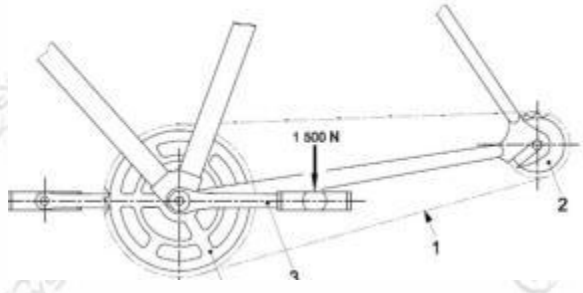
EN 15194																
Clause(s)	Test(s)	Test Remarks	Result													
			N/A													
4.3.5.9	Braking performance	Normal levers	P													
	<table border="1"> <thead> <tr> <th>Condition</th> <th>Brake in use</th> <th>Minimum braking performance value, B_p</th> </tr> </thead> <tbody> <tr> <td rowspan="2">Dry</td> <td>Front only</td> <td>340</td> </tr> <tr> <td>Rear only</td> <td>220</td> </tr> <tr> <td rowspan="2">Wet</td> <td>Front only</td> <td>220</td> </tr> <tr> <td>Rear only</td> <td>140</td> </tr> </tbody> </table>	Condition	Brake in use	Minimum braking performance value, B_p	Dry	Front only	340	Rear only	220	Wet	Front only	220	Rear only	140		P
Condition	Brake in use	Minimum braking performance value, B_p														
Dry	Front only	340														
	Rear only	220														
Wet	Front only	220														
	Rear only	140														
4.3.5.10	Brakes – Heat-resistance test	180N V=12.5km/h >60%	P													
4.3.5.11	Back-pedal brake linearity test		N/A													
4.3.6	Steering		P													
4.3.6.1	Handlebar – Dimensions	<100mm	P													
4.3.6.2	Handlebar grips and plugs		P													
4.3.6.2.1	The ends of the handlebar shall be fitted with handgrips or end plugs. When tested by the method described in 4.3.6.2.2 and 4.3.6.2.3, the handgrips or plugs shall withstand the specified removal forces.		P													
4.3.6.2.2	in water at room temperature for one hour until the handlebar is at a temperature lower than -5°C .	70N, 1min	P													

Test Report

Report No.: KEYS241203038001LD-01

Date: Dec. 18, 2024

Page 10 of 31

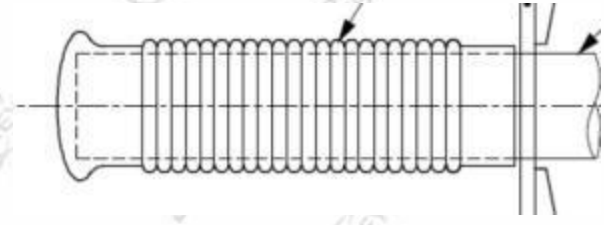
EN 15194			
Clause(s)	Test(s)	Test Remarks	Result
			
4.3.6.2.3	Hot water test method in hot water of +60 °C ± 2 °C for one hour.	100N 1min	P
4.3.6.3	Handlebar stem – Insertion-depth mark or positive stop		P
	a) it shall contain a permanent, transverse mark,		P
	b) it shall incorporates a permanent stop to prevent it from being drawn out of the fork steerer such as to leave the insertion less than the amount specified in a) above		P
4.3.6.4	Handlebar stem to fork steerer – Clamping requirements		P
	the handlebar stem is clamped	<5mm	P
4.3.6.5	Steering stability		P
4.3.6.6	Steering assembly – Static strength and safety tests		P
4.3.6.6.1	Handlebar and stem assembly – Lateral bending test		P
4.3.6.6.1.2	When tested by the method described in 4.3.6.6.1.3, there shall be no cracking or fracture of the handlebar, stem or clamp-bolt and the permanent deformation measured at the point of application of the test force shall not exceed 15 mm	800N 1min, No damaged <3mm	P

Test Report

Report No.: KEYS241203038001LD-01

Date: Dec. 18, 2024

Page 11 of 31

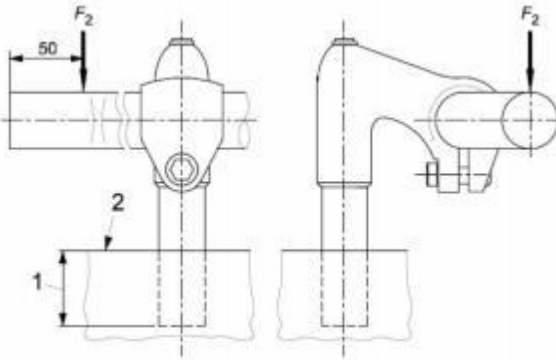
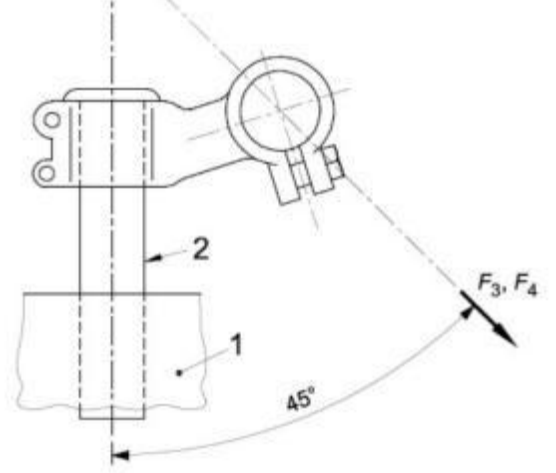
EN 15194			
Clause(s)	Test(s)	Test Remarks	Result
			P
4.3.6.6.2	Handlebar-stem – Forward bending test		P
	When tested by the method described in 4.3.6.6.2.3, there shall be no visible cracks or fractures and the permanent deformation measured at the point of application of the test force and in the direction of the test force shall not exceed 10 mm.	F3: 600N 1min, <2mm F4: 2600N, No cracks	P
			P
4.3.6.6.3	Handlebar to handlebar-stem – Torsional safety test	70Nm No movement	P

Test Report

Report No.: KEYS241203038001LD-01

Date: Dec. 18, 2024

Page 12 of 31

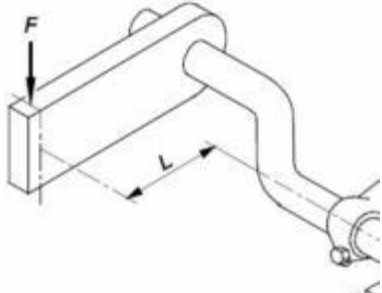
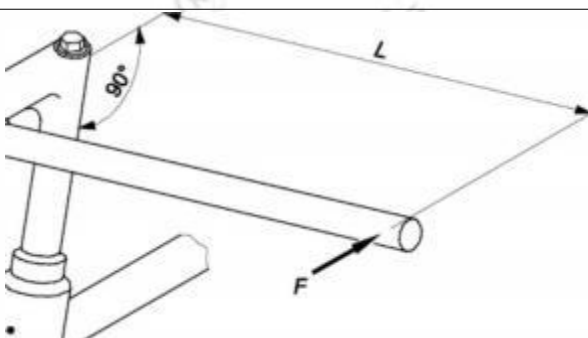
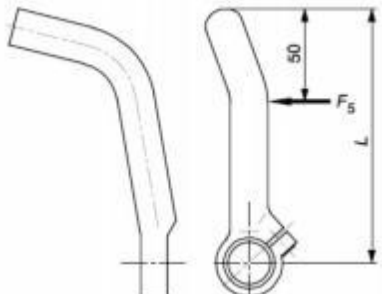
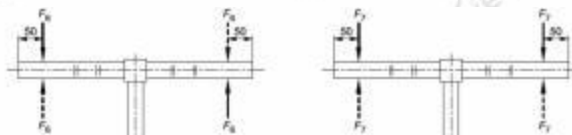
EN 15194			
Clause(s)	Test(s)	Test Remarks	Result
			P
4.3.6.6.4	Handlebar-stem to fork steerer – Torsional safety test	40Nm No move	P
			P
4.3.6.6.5	Bar-end to handlebar – Torsional safety test	300N 1min No move	P
			P
4.3.6.7	Handlebar and stem assembly – Fatigue test	F6: 220N F7: 280N	P
			P
4.3.7	Frames		P

Test Report

Report No.: KEYS241203038001LD-01

Date: Dec. 18, 2024

Page 13 of 31

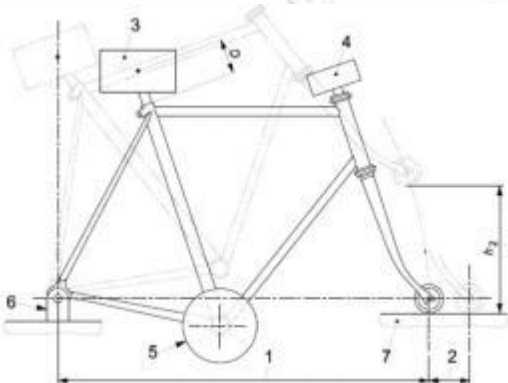
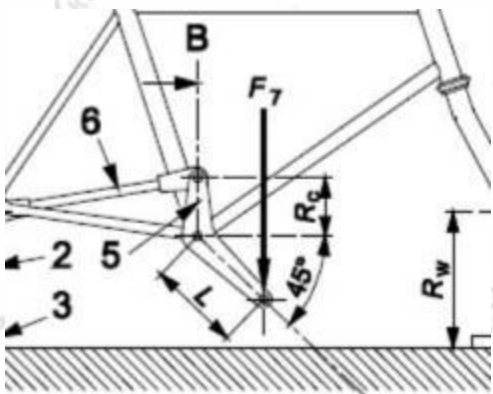
EN 15194			
Clause(s)	Test(s)	Test Remarks	Result
4.3.7.2	Frame – Impact test	Drop height: 360mm A striker of mass 22,5 kg	P
4.3.7.3	Frame and front fork assembly – Impact test	1: 30kg 2: 10kg 3: 50kg Drop height: 300mm	P
			P
4.3.7.4	Frame – Fatigue test with pedalling forces	1000N 100000cycles	P
			P
4.3.7.5	Frame – Fatigue test with horizontal forces	F8: 600N F9: 600N 100000cycles	P

Test Report

Report No.: KEYS241203038001LD-01

Date: Dec. 18, 2024

Page 14 of 31

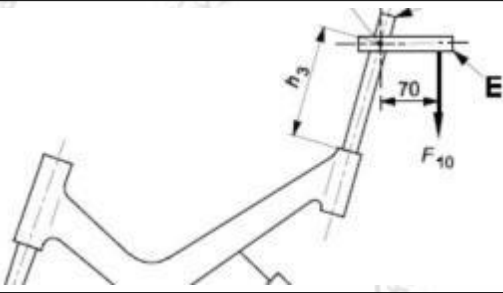
EN 15194			
Clause(s)	Test(s)	Test Remarks	Result
			P
4.3.7.6	Frame – Fatigue test with a vertical force	1100N 50000 cycles	P
			P
4.3.8	Front fork		P
4.3.8.2	Means of location of the axle and wheel retention		P
4.3.8.3.1	Tyre-clearance test	2800N 1min	P
	the tyre shall not contact the crown of the fork nor shall the components separate.		P
4.3.8.3.2	Tensile test	2300N, 1min	P
	there shall be no detachment or loosening of any parts of the assembly and the tubular, telescopic components of any fork-leg shall not separate under the test force.		P
4.3.8.4	Front fork – Static bending test	1500N to 100N	P
	there shall be no fractures or visible cracks in any part of the fork, and the permanent deformation, measured as the displacement of the axis of the wheel-axle or simulated axle in relation to the axis of the fork steerer, shall not exceed 10 mm.		P

Test Report

Report No.: KEYS241203038001LD-01

Date: Dec. 18, 2024

Page 15 of 31

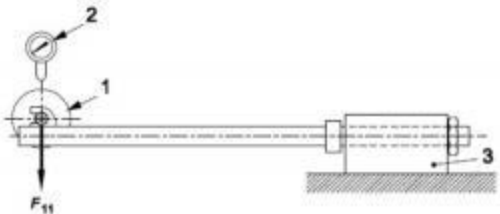
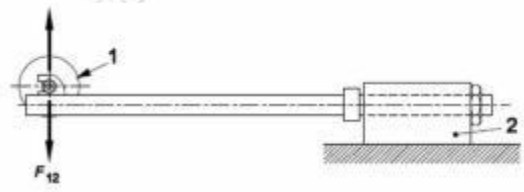
EN 15194			
Clause(s)	Test(s)	Test Remarks	Result
			P
	<p>Locate a deflection measuring device over the loading-attachment in order to measure deflection and permanent deformation of the fork perpendicular to the steerer axis and in the plane of the wheel.</p>		P
4.3.8.5	Front fork – Rearward impact test	22.5kg 360mm 80Nm	P
4.3.8.5.1	Forks made entirely of metal		P
4.3.8.5.2	Forks which have composite parts		P
4.3.8.6	Front fork – Bending fatigue test plus rearward impact test	500N 100000 cycles	P
	<p>there shall be no fractures in any part of the fork, and the permanent deformation, measured as the displacement of the axis of the wheel-axle or simulated axle in relation to the axis of the fork steerer, shall not exceed 45 mm. For composite forks, the running displacement (peak-to-peak value) at the points where the test forces are applied shall not increase by more than 20 % of the initial values</p>		P
			P
4.3.8.7	Forks intended for use with hub- or disc-brakes		P
4.3.8.7.2	Static brake-torque test	1000N 1min, 100N	P

Test Report

Report No.: KEYS241203038001LD-01

Date: Dec. 18, 2024

Page 16 of 31

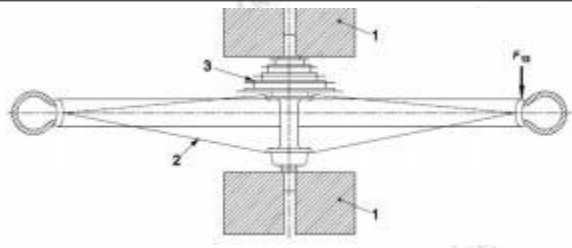
EN 15194			
Clause(s)	Test(s)	Test Remarks	Result
	Apply a rearward force of 1 000 N to the torque arm perpendicular to the fork steerer axis and in the plane of the wheel. Maintain this force for 1 min, then reduce the force to 100 N		P
	there shall be no fractures or visible cracks in any part of the fork.		P
4.3.8.7.4	Brake mount fatigue test	12000 cycles	P
			P
4.3.8.8	Tensile test for a non-welded fork	5000N 1min	P
	there shall be no detachment or loosening of any parts of the assembly.		P
4.3.9	Wheels and wheel/tyre assembly		P
4.3.9.1	Wheels/tyre assembly – Concentricity tolerance and lateral tolerance		P
4.3.9.2	Wheel/tyre assembly – Clearance	<6	P
4.3.9.3	Wheel/tyre assembly – Static strength test	250N 1min	P
			P
4.3.9.4	Wheels – Wheel retention	2300N, 1min	P
	there shall be no relative motion between the axle and the front fork/frame.		P
4.3.9.5	Wheels – Quick-release devices – Operating features		P
	Any quick-release device shall have the following operating features: a) it shall be adjustable to allow setting for tightness; b) its form and marking shall clearly indicate		

Test Report

Report No.: KEYS241203038001LD-01

Date: Dec. 18, 2024

Page 17 of 31

EN 15194			
Clause(s)	Test(s)	Test Remarks	Result
	<p>whether the device is in the open or locked position;</p> <p>c) if adjustable by a lever, the force required to close a properly set lever shall not exceed 200 N and, at this closing force there shall be no permanent deformation of the quick-release device;</p> <p>d) the releasing force of the clamping device when closed shall not be less than 50 N;</p> <p>e) if operated by a lever, the quick-release device shall withstand without fracture or permanent deformation a closing force of not less than 250 N applied with the adjustment set to prevent closure at this force;</p> <p>f) the wheel retention with the quick-release device in the clamped position shall be in accordance with 4.3.9.4.2, 4.3.9.4.3; g) the front wheel retention with the quick-release device in the open position shall be in accordance with 4.3.9.4.3. If applied to a lever, the forces specified in c), d), and e) shall be applied 5 mm from the tip end of the lever.</p>		P
4.3.10	Rims, tyres and tubes		P
4.3.10.2	Tyre inflation pressure		P
	<p>The maximum inflation pressure recommended by the manufacturer shall be permanently marked on the side wall of the tyre so as to be readily visible when the latter is assembled on the wheel. If the rim manufacturer recommends a maximum tyre inflation pressure, it shall be clearly and permanently marked on the rim and also specified in the manufacturer's instructions. It is recommended that the minimum inflation pressure specified by the tyre manufacturer also be permanently marked on the side wall of the tyre.</p>		P
4.3.10.3	Tyre and rim compatibility	<4mm	P

Test Report

Report No.: KEYS241203038001LD-01

Date: Dec. 18, 2024

Page 18 of 31

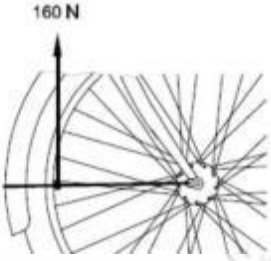
EN 15194			
Clause(s)	Test(s)	Test Remarks	Result
4.3.10.4	Rim-wear		P
	In the case where the rim forms part of a braking system and there is a danger of failure due to wear, the manufacturer shall make the rider aware of this danger by durable and legible marking on the rim, in an area not obscured by the tyre		P
4.3.10.5	Greenhouse effect test for composite wheels	80°C, 4h	P
	no failure of any of the components of the wheel;		P
	no tyre separation from the rim during the test;		P
	no increase in rim width greater than 5 % of the initial maximal width value		P
	compliance of lateral and concentricity tolerance		P
	compliance of tyre and rim compatibility		P
	compliance of static strength		P
4.3.11	Front mudguard		P
	If front mudguard is fitted, when tested by the method described in the two-stage tests in 4.3.11.2 (for mudguard with stays) or 4.3.11.3 (for mudguard without stays), the front mudguard shall not prevent rotation of the wheel or obstruct steering.		P
4.3.11.2	Front mudguard with stays test methods		P
			P
4.3.11.3	Front mudguard without stays test methods		P

Test Report

Report No.: KEYS241203038001LD-01

Date: Dec. 18, 2024

Page 19 of 31

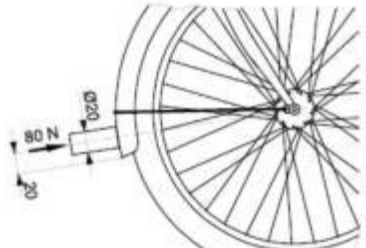
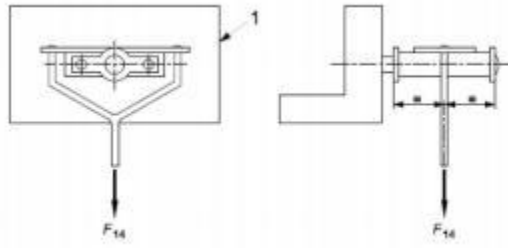
EN 15194			
Clause(s)	Test(s)	Test Remarks	Result
			P
4.3.12	Pedals and pedal/crank drive system		P
4.3.12.1	Pedal tread		P
	The tread surface of a pedal shall be secured against movement within the pedal assembly		P
4.3.12.1.2	Pedals intended to be used without toe-clips, or for optional use with toe-clips, shall have: a) tread surfaces on the top and bottom surfaces of the pedal; or b) a definite preferred position that automatically presents the tread surface to the rider's foot.		P
4.3.12.2	Pedal clearance		P
4.3.12.3	Pedal – Static strength test	1500N, 1min No damaged	N/A
			N/A
4.3.12.4	Pedal – Impact test	15kg, 400mm No damaged	N/A
4.3.12.5	Pedal – Dynamic durability test	80kg, 100000 cycles 180。	N/A
4.3.12.6	Drive-system – Static strength test	1500N	P
4.3.12.7	Crank assembly – Fatigue test	1300N,	N/A

Test Report

Report No.: KEYS241203038001LD-01

Date: Dec. 18, 2024

Page 20 of 31

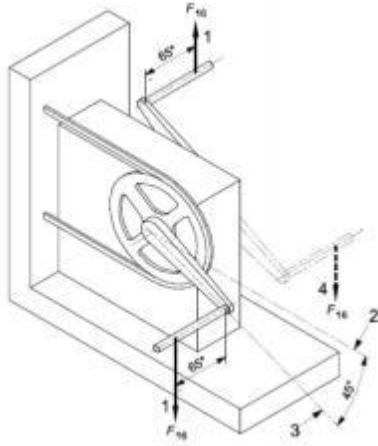
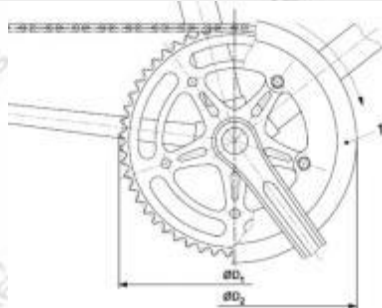
EN 15194			
Clause(s)	Test(s)	Test Remarks	Result
		100000 cycles	
			N/A
4.3.13	Drive-chain and drive belt		P
4.3.13.1	Drive-chain		P
	Where a chain-drive is used as a means of transmitting the motive force, the chain shall operate over the front and rear sprockets without binding. The chain shall conform to the tensile strength and push-out force requirements of ISO 9633.		P
4.3.13.2	Drive belt	4000N No damaged	P
4.3.14	Chain-wheel and belt-drive protective device	D2>D1+10mm	N/A
			N/A
4.3.14.3	Chain and drive belt protective device	>30mm	N/A
4.3.14.4	Combined front gear-change guide	>30mm	N/A

Test Report

Report No.: KEYS241203038001LD-01

Date: Dec. 18, 2024

Page 21 of 31

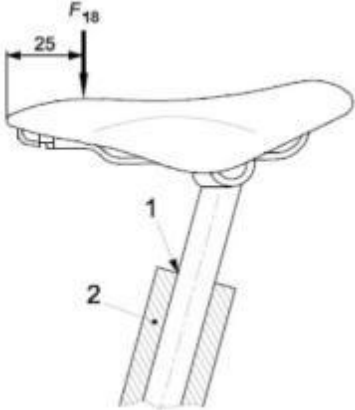
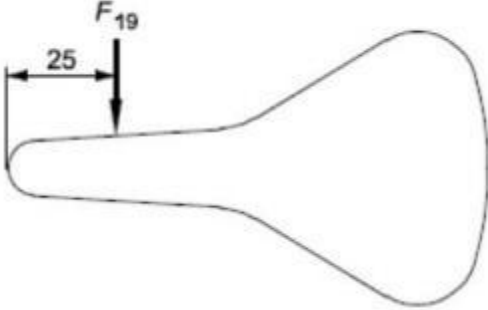
EN 15194			
Clause(s)	Test(s)	Test Remarks	Result
4.3.15	Saddles and seat-posts		P
	No part of the saddle, saddle supports, or accessories to the saddle shall be more than 125 mm above the top saddle surface at the point where the saddle surface is intersected by the seat-post axis.		P
4.3.15.2	Seat-post – Insertion-depth mark or positive stop		N/A
4.3.15.3	Saddle/seat-post – Safety test	F18: 650N 1min No damaged. F19: 250N 1min No damaged	N/A
			N/A
			N/A
4.3.15.4	Saddle – Static strength test	F20: 400N 1min No damaged	N/A

Test Report

Report No.: KEYS241203038001LD-01

Date: Dec. 18, 2024

Page 22 of 31

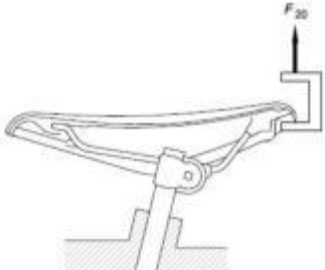
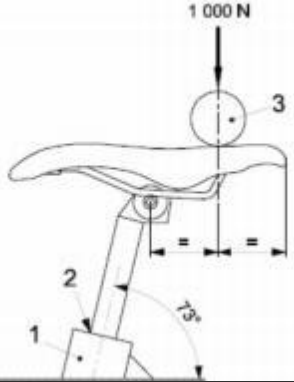
EN 15194			
Clause(s)	Test(s)	Test Remarks	Result
			N/A
			N/A
4.3.15.5	Saddle and seat-post clamp – Fatigue test	1000N 200000 cycles	N/A
			N/A
4.3.15.6	Seat-post – Fatigue test	1000N, 100000 Cycles	N/A

Test Report

Report No.: KEYS241203038001LD-01

Date: Dec. 18, 2024

Page 23 of 31

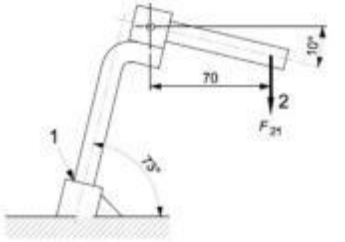
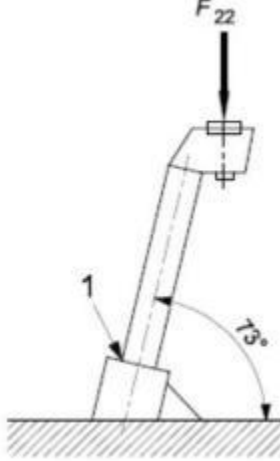
EN 15194			
Clause(s)	Test(s)	Test Remarks	Result
			N/A
		F22: 2000N 1min No damaged	N/A
4.3.16	Spoke protector		P
	EPAC bicycles with multiple free-wheel/cassette sprockets shall be fitted with a spoke-protector guard to prevent the chain interfering with or stopping rotation of the wheel through improper adjustment or damage.		P
4.3.17	Luggage carriers		N/A
4.3.18	Road-test of a fully-assembled EPAC		N/A
4.3.19	Lighting systems and reflectors		P
4.3.19.2	Wiring harness		P
	When a wiring harness is fitted, it shall be positioned to avoid any damage by contact with moving parts or sharp edges. All connections shall withstand a tensile force in any direction of 10 N.		P
4.3.19.3	Lighting systems		P

Test Report

Report No.: KEYS241203038001LD-01

Date: Dec. 18, 2024

Page 24 of 31

EN 15194			
Clause(s)	Test(s)	Test Remarks	Result
	The lighting system consists of a front and a rear light. These devices shall comply with the provisions in force in the country in which the product is marketed. If there are no forced provisions of these devices, the lighting system shall comply with the requirements of ISO 6742-1.		P
4.3.19.4	Reflectors		P
4.3.19.4.2	Rear reflectors		P
4.3.19.4.3	Side reflectors		N/A
4.3.19.4.4	Front reflectors		N/A
4.3.19.4.5	Pedal reflectors		N/A
4.3.20	Warning device		P
	Where a bell or other suitable device is fitted, it shall comply with the provisions in force in the country in which the product is marketed.		P
4.3.21	Thermal hazards		N/A
	A warning shall be placed on the surface if the temperature of the hot accessible surface could be above 60 °C		N/A
4.3.22	Performance levels (PLrs) for control system of EPACs		N/A
4.4	List of significant hazards		P
	The following significant hazards have been considered in this standard: NOTE 1 The risk analysis was focused on EPAC as bicycles for city and trekking, including folding bicycles. Mountain bike and racing bike were not considered. a) Mechanical hazards: high deceleration, high acceleration, Protrusion, instability; kinetic energy; rotating elements and moving elements, rough, slippery surface, sharp edges; b) Electrical hazards: electromagnetic phenomena; electrostatic phenomena; overload; short-circuit; thermal radiation; NOTE 2 The strength of the		P

Test Report

Report No.: KEYS241203038001LD-01

Date: Dec. 18, 2024

Page 25 of 31

EN 15194			
Clause(s)	Test(s)	Test Remarks	Result
	battery holder combination should the EPAC fall to the side will be considered at the next revision. c) Thermal hazards: explosion; flame; radiation from heat sources; d) Ergonomic hazards: effort; lighting; posture; e) Hazards associated with the environment in which the machine is used: water (rain and projection); f) Combination of hazards: braking under wet and dry condition, handgrips, motor management system, engine power management, installed braking power.		
5	Marking, labelling		P
	<ul style="list-style-type: none"> — contact and address of the manufacturer or authorized representative; — EPAC according to EN 15194; — appropriate marking required by legislation (CE); — year of construction, that is the year in which the manufacturing was completed (it is not possible to use a code); — cut off speed XX km/h; — maximum continuous rated power XX kW; — maximum permissible total weight (e.g. marked near the seat post or handlebar); — designation of series or type; — individual serial number if any; — mass if EPAC mass is more than 25 kg — mass of the EPAC in the most usual configuration. 		P
	<ul style="list-style-type: none"> a) visibly and permanently marked with a successive frame number at a readily visible location such as near the pedal-crank, the seat-post, or the handlebar; b) visibly and durably marked, with the name of the manufacturer of complete EPAC or the manufacturer's representative and the number of 		P

Test Report

Report No.: KEYS241203038001LD-01

Date: Dec. 18, 2024

Page 26 of 31

EN 15194			
Clause(s)	Test(s)	Test Remarks	Result
	this document, i.e. EN 15194.; the method of testing for durability is specified in 5.2		
	The following significant hazards have been considered in this standard: NOTE 1 The risk analysis was focused on EPAC as bicycles for city and trekking, including folding bicycles. Mountain bike and racing bike were not considered. a) Mechanical hazards: high deceleration, high acceleration, Protrusion, instability; kinetic energy; rotating elements and moving elements, rough, slippery surface, sharp edges; b) Electrical hazards: electromagnetic phenomena; electrostatic phenomena; overload; short-circuit; thermal radiation; NOTE 2 The strength of the battery holder combination should the EPAC fall to the side will be considered at the next revision. c) Thermal hazards: explosion; flame; radiation from heat sources; d) Ergonomic hazards: effort; lighting; posture; e) Hazards associated with the environment in which the machine is used: water (rain and projection); f) Combination of hazards: braking under wet and dry condition, handgrips, motor management system, engine power management, installed braking power.		P
5	Marking, labelling		P
	<ul style="list-style-type: none"> — contact and address of the manufacturer or authorized representative; — EPAC according to EN 15194; — appropriate marking required by legislation (CE); — year of construction, that is the year in which the manufacturing was completed (it is not possible to use a code); — cut off speed XX km/h; — maximum continuous rated power XX kW; 		P

Test Report

Report No.: KEYS241203038001LD-01

Date: Dec. 18, 2024

Page 27 of 31

EN 15194			
Clause(s)	Test(s)	Test Remarks	Result
	<ul style="list-style-type: none"> — maximum permissible total weight (e.g. marked near the seat post or handlebar); — designation of series or type; — individual serial number if any; — mass if EPAC mass is more than 25 kg — mass of the EPAC in the most usual configuration. 		
	<ul style="list-style-type: none"> a) visibly and permanently marked with a successive frame number at a readily visible location such as near the pedal-crank, the seat-post, or the handlebar; b) visibly and durably marked, with the name of the manufacturer of complete EPAC or the manufacturer's representative and the number of this document, i.e. EN 15194.; the method of testing for durability is specified in 5.2 		P

--- End of Report ---

Test Report

Report No.: KEYS241203038001LD-01

Date: Dec. 18, 2024

Page 28 of 31

Photograph(s) of Sample

Detail of:

☐ front

☐ rear

☐ right side

☐ left side

☐ top

☐ bottom

☐ internal



Detail of:

☐ front

☐ rear

☐ right side

☐ left side

☐ top

☐ bottom

☐ internal

Detail of:

☐ front

Test Report

Report No.: KEYS241203038001LD-01

Date: Dec. 18, 2024

Page 29 of 31

- .. rear
- right side
- .. left side
- .. top
- .. bottom
- .. internal

Detail of:

- p front
- .. rear
- .. right side
- .. left side
- .. top
- .. bottom
- .. internal

Detail of:

- .. front
- p rear
- .. right side
- .. left side

Test Report

Report No.: KEYS241203038001LD-01

Date: Dec. 18, 2024

Page 30 of 31

- .. top
- .. bottom
- .. internal

Detail of:

- front
- rear
- .. right side
- .. left side
- .. top
- .. bottom
- .. internal

Detail of:

- front
- .. rear
- .. right side
- .. left side
- .. top
- .. bottom

Test Report

Report No.: KEYS241203038001LD-01

Date: Dec. 18, 2024

Page 31 of 31

.. internal

Detail of:

p front

.. rear

.. right side

.. left side

.. top

.. bottom

.. internal

*** End of Report ***

KEYS Co., Ltd.