



TEST REPORT

Product Name:	ELECTRIC BICYCLE
Brand Name:	/
Model Number:	PHANTOM-X PHANTOM-X Mini, PHANTOM-X Pro, PHANTOM-X Max
Prepared For :	Changzhou Zhuishi Intelligent Technology Co., Ltd.
Address:	Room 1020, Building 6, Baona Commercial Plaza, Xinbei District, Changzhou City
Prepared By :	Shenzhen DL Testing Technology Co., Ltd.
Address:	101-201, Comprehensive Building, Tongzhou Electronics Longgang Factory Area, No.1 Baolong Fifth Road, Baolong Community, Baolong Street, Longgang District, Shenzhen, China
Date of Receipt:	Aug. 20, 2025
Test Date:	Aug. 20, 2025 - Sep. 04, 2025
Date of Report :	Sep. 04, 2025
Report No.:	DLS-250825019R



EST REPORT EN 15194:2017 Cycles - Electrically power assisted cycles - EPAC Bicycles EN ISO12100:2010 Safety of machinery - General principles for design - Risk assessment and risk reduction	
Report Number	DLS-250825019R
Tested by (name)	Nash Zou
Compiled by (name)	Ray Liang
Approved by (name)	Jade Yang
Date of issue	Sep. 04, 2025
Total number of pages	64 pages
Testing Laboratory	Shenzhen DL Testing Technology Co., Ltd.
Address	101-201, Comprehensive Building, Tongzhou Electronics Longgang Factory Area, No.1 Baolong Fifth Road, Baolong Community, Baolong Street, Longgang District, Shenzhen, China
Applicant's name	Changzhou Zhuishi Intelligent Technology Co., Ltd.
Address	Room 1020, Building 6, Baona Commercial Plaza, Xinbei District, Changzhou City
Test specification:	
Standards	EN 15194:2017+A1:2023, EN ISO12100:2010
Test procedure	Test report MD (2006/42/EC)+LVD(2014/35/EU)
Non-standard test method	N/A
Test Report Form No	EN15194
Test Report Form(s) Originator	DL
Master TRF	SCC/ITD/KD
This test report is specially limited to the above client company and product model only. It may not be duplicated without prior written consent of Testing Laboratory.	
Test item description	ELECTRIC BICYCLE
Trade Mark	/
Manufacturer	Changzhou Zhuishi Intelligent Technology Co., Ltd. Room 1020, Building 6, Baona Commercial Plaza, Xinbei District, Changzhou City
Model/Type reference	PHANTOM-X (For additional models, see page 1)
Ratings	54.6V---2.0A Battery Capacity: 48V 15AH



Possible test case verdicts

Test case does not apply to the test object : N/A

Test object does meet the requirement..... : P(ass)

Test object does not meet the requirement..... : F(ail)

Test Verdict **PASS**

General remarks

“(see remark #)” refers to a remark appended to the report.

“(see appended table)” refers to a table appended to the report.

Throughout this report a comma is used as the decimal separator.

The test results presented in this report relate only to the object tested.

This report shall not be reproduced except in full without the written approval of the testing laboratory.

General descriptions

Ambient temperature: 20-25°C humidity: 54-60%

The EMC section is in a separate report.

DRAFT



Test Summary

1. Scope

This European standard is intended to cover electrically power assisted cycles of a type which have a maximum continuous rated power of 250W, of which the output is progressively reduced and finally cut off as the vehicle reaches a speed of 25 km/h, or sooner, if the cyclist stops pedaling, and access the design and assembly of electrically power assisted bicycles and sub-assemblies for systems using battery voltage up to 48VDC integrated a battery charger with 100-240V a.c. input.

2. Number of tested Sample

Complete test was conducted on PHANTOM-X.

2 sets of fully assembled bicycle, 2 pieces of frame, 2 pieces of front fork, 1 piece of handlebar, 1 piece of stem, 1 piece of seat post, 1 piece of saddle, 2 pieces of luggage carrier, 4 pieces of chain, 4 pieces of bell, 4 pieces of brake pad, 3 pieces of motor, 2 pieces of controller, 2 pieces of sensor.

3. Conclusion

The application model(s) are in compliance with the requirements of the standards EN 15194:2017+A1:2023 & EN ISO 12100:2010.

DRAFT



EN 15194			
Clause	Requirement	Test Result	Remark Verdict
1	Scope	Informative	P
	This European Standard applies to EPAC bicycles for private and commercial use with exception of EPAC intended for hire from unattended station.		P
	This European Standard is intended to cover all common significant hazards, hazardous situations and events (see Clause 4) of electrically power assisted bicycles, when used as intended and under condition of misuse that are reasonably foreseeable by the manufacturer.		P
	This European Standard is intended to cover electrically power assisted bicycles of a type which have a maximum continuous rated power of 0,25 kW, of which the output is progressively reduced and finally cut off as the EPAC reaches a speed of 25 km/h, or sooner, if the cyclist stops pedalling.		P
	This European Standard specifies requirements and test methods for engine power management systems, electrical circuits including the charging system for the design and assembly of electrically power assisted bicycles and sub-assemblies for systems having a rated voltage up to and including 48 V d.c. or integrated battery charger with a nominal 230 V a.c. input.		P
	This European Standard specifies safety and safety related performance requirements for the design, assembly, and testing of EPAC bicycles and subassemblies intended for use on public roads, and lays down guidelines for instructions on the use and care of such bicycles.		P
	This European Standard applies to EPAC bicycles that have a maximum saddle height of 635 mm or more and that are intended for use on public roads.		P
	This European Standard is not applicable to EPACs which are manufactured before the date of its publication as EN.		P
2	Normative references	Informative	P
3	Terms and definitions	Informative	P
4	Safety requirements and/or protective measures		P
4.1	General		P
	EPAC shall be designed according to the principles of EN ISO 12100 for relevant but not significant hazards, which are not dealt with by this document. It includes evaluation of such risks for all relevant components.	No such hazards EN ISO 12100 complied	P
	Means shall be provided to the user to prevent an unauthorized use of the EPAC e.g. key, locks, electronic control device.	key, locks, electronic control device equipped	P
4.2	Electrical requirements		P
4.2.1	Electric circuit		P
	The electrical control system shall be designed so that, should it malfunction in a hazardous manner, it shall switch off power to the electric motor without causing a		P



	hazardous situation and it requires user interaction to switch on again.		
4.2.2	Controls and symbols		P
	If symbols are used, their meaning shall be described in the instructions for use. "On" "Off" symbols, lightings symbols, start-up assistance symbols, audible warning device symbols design shall be in accordance with those described in Annex I and Annex J.		P
	A master control device shall be fitted to switch on and shut off the assistance, which shall be apparent, easy to reach and unmistakable.		P
	This master control device shall be activated by voluntary action to enable all assistance modes (start up and pedalling) before use of the EPAC.		P
4.2.3	Batteries	See table 4.2.3	P
4.2.3.1	Requirements		P
	<p>a) The EPAC and batteries pack shall be designed in order to avoid risk of fire and mechanical deterioration resulting from abnormal use. Compliance is checked by the test described in 4.2.3.2.</p> <p>b) During the test the EPAC and the batteries shall not emit flames, molten metal or poisonous ignitable gas in hazardous amounts and any enclosure shall show no damage that could impair compliance with this European Standard. Safety and compatibility of the battery/charger combination shall be ensured, according to the manufacturer's specifications.</p> <p>c) The battery terminals shall be protected against creating an accidental short circuit.</p> <p>d) An appropriate care shall be taken to ensure that the batteries are protected against overcharging. An appropriate overheating and short circuit protection device shall be fitted.</p>	<p>No such hazards No flame found during the test. No damage, molted metal or poisonous nnitable gas found afet the test</p>	P
	Batteries and the charger unit shall be labelled in order to be able to check their compatibility.		P
4.2.4	Battery charger		P
	Chargers for EPAC are considered to be operated in a residential (household) environment.	EN 60335-2-29 complied	P
4.2.5	Electric cables and connections		P
4.2.5.1	General		P
	All connectors for cable and wire shall be selected to prevent corrosion of electrical contact conductance.		P
4.2.5.2	Requirements		P
	Cable and plug temperature shall be lower than that specified by the manufacturer of the cables and plugs. Damage to cable and plug insulation shall be prevented.		P
	The cable cross sections shall be selected in accordance to EN 60335-1:2012, Table 11. If these requirements are not met, a temperature rise test shall be performed, in accordance to 4.2.5.3.		P
4.2.6	Wiring	See table 4.2.6	P
	Requirements on wiring shall be checked according to the following sequence at an ambient room temperature		P



	<p>(20 ± 5) °C.</p> <p>a) Wire ways shall be smooth and free from sharp edges.</p> <p>b) Wires shall be protected so that they do not come into contact with burrs, cooling fins or similar sharp edges that may cause damage to their insulation. Holes in metal through which insulated wires pass shall have smooth well-rounded surfaces or be provided with bushings.</p> <p>c) Wiring shall be effectively prevented from coming into contact with moving parts. Compliance with a), b), c) shall be checked by inspection.</p> <p>d) Separate parts of the EPAC that can move in normal use or during user maintenance relative to each other, shall not cause undue stress to electrical connections and internal conductors, including those providing ground continuity.</p>		
	If an open coil spring is used to protect wire, it shall be correctly installed and insulated. Flexible metallic tubes shall not cause damage to the insulation of the conductors contained within them.		P
	Compliance with d) shall be checked by inspection and by the following test method.		P
	If flexing occurs in normal use, the appliance is placed in its normal operational position and is supplied at rated voltage under normal operation.		P
	The movable part is moved backwards and forwards through the largest angle permitted by its construction, so that the conductor is flexed.		P
	For conductors that are flexed in normal use, flex movable part for 10 000 cycles at a test frequency of 0,5 Hz.		P
	For conductors that are flexed during user maintenance, flex the movable part for 100 cycles at the same frequency.		P
4.2.7	Power cables and conduits		N/A
	Conduit entries, cable entries and knockouts shall be constructed or located so that the introduction of the conduit or cable does not reduce the protection measures adopted by the manufacturer.	external power adapter Used	N/A
	Guidance for power cables size selection is given in HD 60364-5-52:2011, 5.22.1.2, 523.1523.3 and Table A.		N/A
	The insulation of internal wiring shall withstand the electrical stress likely to occur in normal use.		N/A
	The wiring and its connections shall withstand the electrical strength test. The test voltage expressed in V shall be equal to(+500 2xUr) for 2 min and applied between live parts and other metal parts only.		N/A
4.2.8	External and internal electrical connections		P
	Electrical connection shall comply with HD 60364-5-52:2011, 526.1 and 526.2.		P
4.2.9	Moisture resistance		P
	The electrical components of a fully assembled EPAC shall be tested and shall comply with IPX4 requirements according to EN 60529:1991.	IPX4	P



4.2.10	Mechanical strength test		P
	<p>The electrical components including the battery shall have adequate mechanical strength and be constructed to withstand such rough handling that may be expected in normal use. Compliance is checked by:</p> <p>— Applying impacts to the battery pack mounted on the EPAC by means of the spring hammer as specified in EN 60068-2-75. The battery pack is rigidly supported and three impacts are applied to every point of the enclosure that is likely to be weak with an impact energy of $(0,7 \pm 0,05)$ J. After the test the battery pack shall show no damage that could impair compliance with this European Standard;</p> <p>— Detachable batteries are submitted to free fall on a rigid surface as specified in EN 22248 at a height of 0,90 m in three different positions. The positions shall be one surface, one edge and one corner of the enclosure that is likely to be weak.</p>		P
	<p>After the test the battery pack shall show no damage that could lead to emission of dangerous substances (gas or liquid) ignition, fire or overheating.</p>	<p>No damage found after the test No dangerous substances (gas or liquid) ignition, fire or overheating found after the test</p>	P
4.2.11	Maximum speed for which the electric motor gives assistance		P
4.2.11.1	Requirements		P
	<p>The electrical motor assistance shall stop when the EPAC reaches a speed of 25 km/h or lower speed if limited by design.</p>	<p>The electrical motor assistance will voluntary stop while speed >25 km/h</p>	P
	<p>The maximum speed of the EPAC for which the electric motor gives assistance shall not differ by more than +10 % from the maximum assistance speed indicated in the marking required by Clause 5 when determined according to the test method described in 4.2.11.2.</p>		P
4.2.12	Start-up assistance mode		P
4.2.12.1	Requirements		P
	<p>An EPAC can be equipped with a start-up assistance mode that operates up to a maximum speed of 6 km/h.</p>	<p>Start-up assistance mode supported. Max. Speed <6 km/h</p>	P
	<p>This mode shall be activated by the voluntary and maintained action of the user either when riding without pedalling or when the user is pushing the cycle.</p>		P
4.2.13	Power management	See table 4.2.13	P
4.2.13.1	Requirements		P
	<p>a) When tested by the method described in 4.2.13.2 the recordings shall show that assistance shall be provided only when the cyclist pedals forward. This requirement shall be checked according to the test methods described in 4.2.13.2.3; \ b) assistance shall be cut off when the cyclist stops pedalling forward and the cut-off distance shall not exceed 2 m;</p>		P



	<p>c) If all braking devices (e.g. levers, back pedal) are equipped with cut-off switches, the cut off distance shall not exceed 5 m;</p> <p>d) the power output or assistance shall be progressively reduced (see Annex B) and finally cut off as the EPAC reaches the maximum assistance speed as designed. This requirement shall be checked according to the test methods described in 4.2.13.2;</p> <p>e) the assistance shall be progressively and smoothly managed (e.g. no hunting);</p> <p>f) two independent applying actions shall be required to start the electrical assistance mode (e.g. power switch and forward pedalling activation); a traffic caused stop (e.g. traffic lights) is not subject to this requirement;</p> <p>g) after a deactivation of the electrical assistance mode due to any hazardous electric drive malfunction, the electric drive shall not start automatically without rider intervention (pedalling is not considered as rider intervention).</p>		
4.2.14	Maximum power measurement — Measurement at the engine shaft		P
	The maximum continuous rated power shall be measured according to EN 60034-1 when the motor reaches its thermal equilibrium as specified by the manufacturer.	EN 60034-1 complied	P
	In circumstance where the power is measured directly at the shaft of the electronic motor, the result of the measurement shall be divided by 1,10 to consider the measurement uncertainty and then divided by 1,05 to include for example the transmission losses, unless the real values of these losses are determined.		P
4.2.15	Electro Magnetic Compatibility	See Annex A	P
4.2.15.1	Emission		P
4.2.15.2	Immunity		P
4.2.15.3	Battery charger		P
	As an EPAC is not intended to be used while charging on the electric network, for integrated charger the whole EPAC plus integrated charger shall be tested for EMC according to the applicable standards based on the European EMC directive.		P
	The following European Standards are applicable for battery chargers to be used in residential environment: EN 55014-1, EN 55014-2, EN 61000-3-2, EN 61000-3-3.	EN EN 55014-1, EN 55014-2, EN 61000-3-2, EN 61000-3-3 complied	P
4.2.16	Failure mode		P
4.2.16.1	Requirements		P
	It shall be possible to ride the EPAC by pedalling even if the assistance failed.	The rider can keep ride the EPAC by pedalling even if the assistance failed the EPAC by pedalling even if the assistance failed	P
	This requirement shall be checked as described in 4.2.16.2.		P



4.2.17	Anti-tampering measure		P
4.2.17.1	General		P
	Anti-tampering measures apply to tampering or modifications that general consumers carry out concerning the control unit, drive unit or other parts of power assisting system by using commercially available tools, equipment or parts.		P
4.2.17.2	Prevention of tampering of the motor		P
	The following anti-tampering requirements shall be taken into account:		P
	a) Anti-tampering relevant parameters indicated below shall only be accessible to the manufacturer or authorized persons and changes of software configuration parameters require programming tools that are not commercially available or security protected: 1) maximum speed with motor assistance (all systems), 2) parameters affecting the maximum vehicle speed limited by design, 3) maximum gear ratio (system with middle motors), 4) maximum motor power (all systems), 5) maximum speed of starting up assistance;		P
	b) Assumable manipulations on the approval relevant configuration shall be prevented or compensated by effective counter measures, i.e. plausibility logics to detect manipulations on sensors;		P
	c) Closed set of components (i.e. operation only with released battery);		P
	d) Protection against opening of relevant components without traces (sealing).		P
4.3	Mechanical requirements		P
4.3.1	General		P
4.3.1.1	Definition of brake tests		P
	Brake tests to which accuracy requirements apply, as in 4.3.1.4, are those specified in 4.3.5.3 to 4.3.5.6 inclusive.		P
4.3.1.2	Definition of strength tests		P
	Strength tests to which accuracy requirements apply, as in 4.3.1.4, are those involving static, impact or fatigue loading as specified in 4.3.5.6 to 4.3.12, 4.3.13 inclusive and 4.3.19.2.		P
4.3.1.3	Numbers and condition of specimens for the strength tests		P
	In general, for static, impact and fatigue tests, each test shall be conducted on a new test sample, but if only one sample is available, it is permissible to conduct all of these tests on the same sample with the sequence of testing being fatigue, static and impact.		P
	When more than one test is conducted on the same sample, the test sequence shall be clearly recorded in the test report or record of testing.		P
	In all strength tests, specimens shall be in the fully-finished condition.		P
4.3.1.4	Accuracy tolerances of test conditions for brake tests and strength tests		P



	Unless stated otherwise, accuracy tolerances based on the nominal values shall be as follows: Forces and torques 0/+5 % Masses and weights ± 1 % Dimensions ± 1 mm Angles $\pm 1^\circ$ Time duration ± 5 s Temperatures ± 2 °C Pressures ± 5 %		P
4.3.1.5	Fatigue test		P
	The force for fatigue tests shall be applied and released progressively, not to exceed 10 Hz. The tightness of fasteners according to manufacturer's recommended torque can be re-checked not later than 1 000 test cycles to allow for the initial settling of the component assembly. (This is considered applicable to all components, where fasteners are present for clamping.) The test bench shall be qualified to meet dynamic requirements of 4.3.1.4.		P
4.3.1.6	Fatigue test for composite components		P
	For fatigue test for composite components, the initial value of displacement (peak-to-peak value) is taken after 1 000 cycles and before 2 000 cycles.	2000 cycles tested	P
4.3.1.7	Plastic material test ambient temperature		P
	All strength tests involving any plastic materials shall be pre-conditioned for two hours and tested at an ambient temperature of $23\text{ °C} \pm 5\text{ °C}$.	25°C	P
4.3.1.8	Crack detection methods		P
	Standardized methods should be used to emphasize the presence of cracks where visible cracks are specified as criteria of failure in tests specified in this standard.	No visible crack found	P
4.3.2	Sharp edges		P
	Exposed edges that could come into contact with the rider's hands, legs, etc., during normal riding or normal handling and normal maintenance shall not be sharp, e.g. deburred, broken, rolled or processed with comparable techniques.	No sharp edges found	P
4.3.3	Security and strength of safety-related fasteners		P
4.3.3.1	Security of screws		P
	Any screws used in the assembly of suspension systems or screws used to attach bracket attached electric generators, brake-mechanisms and mud-guards to the frame or fork, and the saddle to the seat-post shall be provided with suitable locking devices, e.g. lock-washers, lock-nuts, thread locking compound or stiff nuts.		P
4.3.3.2	Minimum failure torque		P
	The minimum failure torque of bolted joints for the fastening of handle bars, handlebar-stems, bar-ends, saddle and seat-posts shall be at least 50 % greater than the manufacturer's recommended tightening torque.		P
4.3.3.3	Folding bicycles mechanism		P
	If provided, folding bicycle mechanism shall be designed		P



	so that EPAC can be locked for use in a simple, stable, safe way and when folded no damage shall occur to any cables. No locking mechanism shall contact the wheels or tyres during riding, and it shall be impossible to unintentionally loosen or unlock the folding mechanisms during riding.		
4.3.4	Protrusions		P
	These requirements are intended to address the hazards associated with the users of EPACs falling on projections or rigid components (e.g. handlebars, levers) on EPAC possibly causing internal injury or skin puncture. Tubes and rigid components in the form of projections which constitute a puncture hazard to the rider should be protected. The size and shape of the end protection has not been stipulated, but an adequate shape shall be given to avoid puncturing of the body. Screw threads which constitute a puncture hazard shall be limited to a protrusion length of one major diameter of the screw beyond the internally threaded mating part.		P
4.3.5	Brakes		P
4.3.5.1	Braking-systems		P
	EPAC shall be equipped with at least two independently actuated braking-systems. At least one shall operate on the front wheel and one on the rear wheel. The braking-systems shall operate without binding and shall be capable of meeting the braking-performance requirements of 4.3.5.9.		P
	No hand shall need to be taken from the handlebar to operate the brake levers.		P
	If additional braking-systems are implemented, they shall meet the brake requirements of 4.3.5.		P
	Brake-blocks containing asbestos shall not be used.		P
4.3.5.2	Hand-operated brakes		P
4.3.5.2.1	Brake-lever position		P
	The brake levers for front and rear brakes shall be positioned according to the legislation or custom and practice of the country in which EPAC is to be sold, and EPAC manufacturer shall state in the manufacturer's instructions which levers operate the front and rear brakes (see also Clause 6 i)).		P
4.3.5.2.2	Brake-lever grip dimensions		P
4.3.5.2.2.1	Requirement		P
	The dimension, d, measured between the outer surfaces of the brake-lever in the region intended for contact with the rider's fingers and the handlebar or any other covering present shall over a distance of not less than 40 mm as shown in Figure 1 not exceed 90 mm.		P



	Conformance shall be established by the method detailed in 4.3.5.2.2.2.		P
	The range of adjustment on the brake-lever ought to permit these dimensions to be obtained.		P
4.3.5.3	Attachment of brake assembly and cable requirements		P
	Cable pinch-bolts shall not sever any of the cable strands when assembled to the manufacturer's instructions. In the event of a cable failing, no part of the brake mechanism shall inadvertently inhibit the rotation of the wheel.		P
	The cable end shall either be protected with a cap that shall withstand a removal force of not less than 20 N or be otherwise treated to prevent unravelling.		P
4.3.5.4	Brake-levers – Position of applied force		P
	For the purposes of braking tests in this standard, for brake-levers similar to Type A, the test force shall be applied at a distance, b , which is equal to either dimension a as determined in 4.3.5.2.2.2 or 25 mm from the free end of the brake-lever, whichever is the greater (see Figure 4).		P
			P
4.3.5.5	Brake-block and brake-pad assemblies – Safety test		P
4.3.5.5.1	Requirement		P
	The friction material shall be securely attached to the holder, backing-plate, or shoe and there shall be no failure of the braking system or any component thereof when tested by the method specified in 4.3.5.5.2.		P
4.3.5.6	Brake adjustment		P
	Each brake shall be equipped with an adjustment mechanism either manual or automatic.	Manual adjustment were equipped	P
	Each brake shall be capable of adjustment with or without the use of a tool to an efficient operating position		P



	until the friction material has worn to the point of requiring replacement as recommended in the manufacturer's instructions. Also, when correctly adjusted, the friction material shall not contact anything other than the intended braking surface.		
	The brake blocks of a bicycle with rod brakes shall not come into contact with the rim of the wheels when the steering angle of the handlebars is set at 60°, nor shall the rods be bent, or be twisted after the handlebars are reset to the central position.		P
4.3.5.7	Hand-operated braking-system – Strength test		P
4.3.5.7.1	Requirement		P
	When tested by the method described in 4.3.5.7.2, there shall be no failure of the braking-system or of any component thereof.	No failure of the braking-system found after the test	P
4.3.5.8	Back-pedal braking system – Strength test		P
4.3.5.8.1	General		P
	If a back-pedal braking system is fitted, the brake shall be actuated by the operator's foot applying force to the pedal in a direction opposite to that of the drive force. The brake mechanism shall function regardless of any drive-gear positions or adjustments. The differential between the drive and brake positions of the crank shall not exceed 60°.		P
	The measurement shall be taken with the crank held against each position with a pedal force of at least 250 N. The force shall be maintained for 1 min in each position.		P
4.3.5.8.2	Requirement		P
	When tested in accordance with 4.3.5.8.3, there shall be no failure of the brake system or any component thereof.	1500N 1min The braking system is correctly adjusted No failure or damage found after the test	P
4.3.5.9	Braking performance		P
4.3.5.9.1	General		P
	The progressive characteristics of the brake are determined by linearity measurements. A final, simple track test checks for smooth, safe, stopping characteristics.		P
	Conduct the braking-performance test on a fully-assembled bicycle after the brakes have been subjected to the strength test detailed in 4.3.5.7, 4.3.5.8. Before testing the bicycle, inflate the tyres and adjust the brakes all according to the manufacturer's instructions, but in the case of rim-brakes to the maximum clearance		P



	specified by the manufacturer.																										
4.3.5.9.2	Requirements			P																							
	<p>Where EPAC is fitted with secondary brake-levers attached to brake-levers, bar-ends or aerodynamic extensions, separate tests shall be conducted for the operation of the secondary brake-levers in addition to tests with the normal levers.</p> <p>Table 1 — Calculated braking performance value</p> <table border="1"> <thead> <tr> <th>Condition</th> <th>Brake in use</th> <th>Minimum braking performance value, B_p</th> </tr> </thead> <tbody> <tr> <td rowspan="2">Dry</td> <td>Front only</td> <td>340</td> </tr> <tr> <td>Rear only</td> <td>220</td> </tr> <tr> <td rowspan="2">Wet</td> <td>Front only</td> <td>220</td> </tr> <tr> <td>Rear only</td> <td>140</td> </tr> </tbody> </table>	Condition	Brake in use	Minimum braking performance value, B_p	Dry	Front only	340	Rear only	220	Wet	Front only	220	Rear only	140	<table border="1"> <tr> <td rowspan="2">D r y</td> <td>Front</td> <td>376</td> <td rowspan="4">P</td> </tr> <tr> <td>Rear</td> <td>282</td> </tr> <tr> <td rowspan="2">W E t</td> <td>Front</td> <td>253</td> </tr> <tr> <td>Rear</td> <td>162</td> </tr> </table>	D r y	Front	376	P	Rear	282	W E t	Front	253	Rear	162	
Condition	Brake in use	Minimum braking performance value, B_p																									
Dry	Front only	340																									
	Rear only	220																									
Wet	Front only	220																									
	Rear only	140																									
D r y	Front	376	P																								
	Rear	282																									
W E t	Front	253																									
	Rear	162																									
4.3.5.9.3	Linearity requirements			P																							
	When tested by the methods described in 4.3.5.9.5.6 c) 1) and 2), the braking force FBr average shall be linearly proportional (within $\pm 20\%$) to the progressively increasing intended operating forces FOp intend. The requirement applies to braking forces FBr average equal to and greater than 80 N (according to Annex F).			P																							
4.3.5.9.4	Ratio between wet and dry braking performance requirements			P																							
	In order to ensure safety for both wet and dry braking, the ratio of braking performance wet: dry shall be greater than 4:10.	wet: dry ratio:>4:10		P																							
	The methods for calculating this ratio are given in 4.3.5.9.5.6 g).			P																							

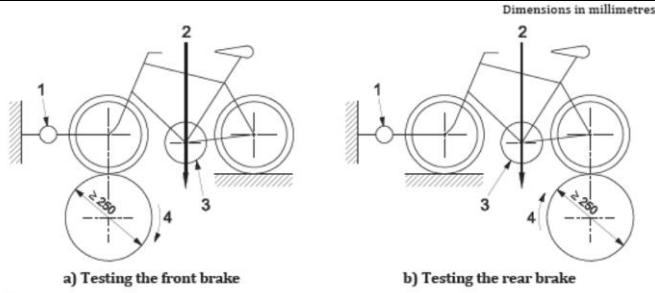
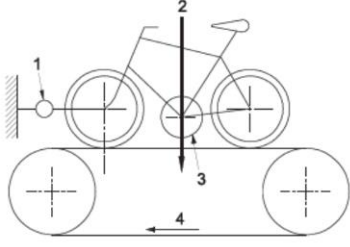
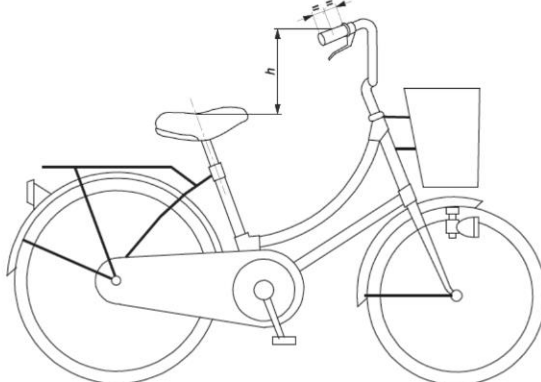
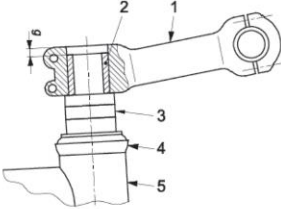
	 <p>a) Testing the front brake b) Testing the rear brake</p> <p>Key</p> <p>1 braking-force transducer 2 applied force, or 3 additional mass 4 direction of drum rotation</p> <p>Figure 6 — Braking performance test-machine-Single drum type</p>  <p>Key</p> <p>1 braking-force transducer 2 applied force, or 3 additional mass 4 direction of belt travel</p> <p>Figure 7 — Braking performance test-machine-Driven belt type</p>		
4.3.5.9.5.5	Vertical force on the tested wheel		P
	The wheel to be tested shall be forced vertically downwards so that no skidding of the wheel occurs when tested according to 4.3.5.9.5.6 c) 1) and 2).	No skidding of the wheel occurred during the test	P
	It is permitted that the necessary force be applied anywhere on the bicycle (wheel-axle, bottom bracket, seat-post, etc.) provided that it is exerted vertically downwards.		P
4.3.5.10	Brakes – Heat-resistance test		P
4.3.5.10.1	General		P
	This test applies to all disc- and hub-brakes but to rim-brakes only where they are known or suspected to be manufactured from or include thermoplastic materials.		P
	Each brake on the bicycle shall be tested individually, but where the front and rear brakes are identical only one brake need be tested.		P
4.3.5.10.2	Requirement		P
	Throughout the test described in 4.3.5.10.3, the brake-lever shall not touch the handlebar-grip, the operating force shall not exceed 180 N, and the braking force shall not deviate outside the range 60 N to 115 N.		P
	Immediately after having been subjected to the test described in 4.3.5.10.3, the brakes shall achieve at least 60 % of the braking performance which was recorded at the highest operating force used during the performance tests 4.3.5.9.5.6 c) 1) and 2).		P

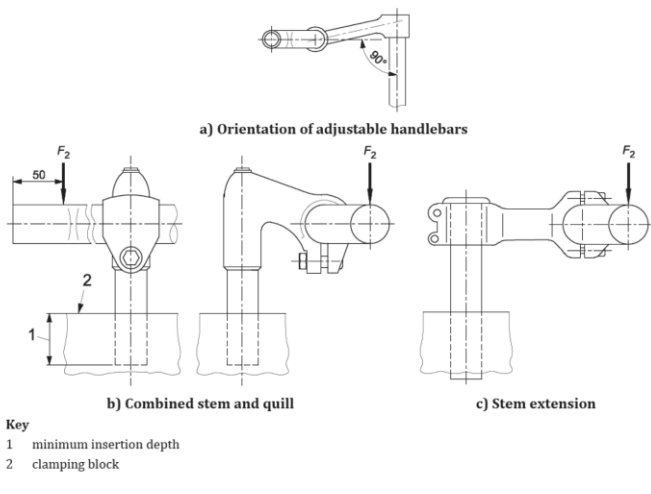


Table 2 — Total braking energy					
<table border="1" style="margin: auto;"> <tr> <td style="padding: 5px;">Total braking energy, <i>E</i></td> <td style="text-align: center; padding: 5px;">75</td> </tr> </table>		Total braking energy, <i>E</i>	75		
Total braking energy, <i>E</i>	75				
4.3.5.11	Back-pedal brake linearity test		P		
	This test shall be conducted on a fully assembled EPAC. The output force for a back-pedal brake shall be measured tangentially to the circumference of the rear tyre, when the wheel is rotated in the direction of forward movement, while a force of between 90 N and 300 N is being applied to the pedal at right angles to the crank and in the direction of braking.		P		
	The braking force reading shall be taken during a steady pull and after one revolution of the wheel. A minimum of five results, each at a different pedal force level, shall be taken. Each result shall be the average of three individual readings at the same load level.		P		
	The results shall be plotted on a graph, showing the line of best fit and the $\pm 20\%$ limit lines obtained by the method of least squares outlined in Annex F.		P		
4.3.6	Steering		P		
4.3.6.1	Handlebar – Dimensions		P		
	<p>Adjust the handlebar height to its highest normal riding position and the saddle to its lowest normal riding position as specified by the manufacturer (see Clause 6 i)). Measure the vertical distance from the centre and top of the handlebar grips to a point where the saddle surface is intersected by the seat post axis (see Figure 9). This dimension shall not exceed 400 mm.</p>  <p style="font-size: small;">Key h vertical distance</p> <p style="text-align: center; font-size: small;">Figure 9 — Vertical distance between the handlebar grips and the seat surface</p>	<400mm	P		
4.3.6.2	Handlebar grips and plugs		P		
4.3.6.2.1	Requirements		P		
	The ends of the handlebar shall be fitted with handgrips or end plugs. When tested by the method described in 4.3.6.2.2 and 4.3.6.2.3, the handgrips or plugs shall withstand the specified removal forces.	The handgrips or plugs could withstand the specified removal forces during the test	P		



4.3.6.3	Handlebar stem – Insertion-depth mark or positive stop		P
	<p>The handlebar-stem shall be provided with one of the two following alternative means of ensuring a safe insertion depth into the fork steerer:</p> <ul style="list-style-type: none"> 、 a) it shall contain a permanent, transverse mark, of length not less than the external diameter of the stem, that clearly indicates the minimum insertion depth of the handlebar-stem into the fork steerer. The insertion mark shall be located at a position not less than 2,5 times the external diameter of the handlebar-stem from the bottom of the stem, and there shall be at least one stem diameter's length of contiguous, circumferential stem material below the mark; b) it shall incorporates a permanent stop to prevent it from being drawn out of the fork steerer such as to leave the insertion less than the amount specified in a) above. 		P
4.3.6.4	Handlebar stem to fork steerer – Clamping requirements		P
	<p>The distance g, see Figure 11, between the top of the handlebar stem and the top of the fork steerer to which the handlebar stem is clamped shall not be greater than 5 mm.</p> <p>The upper part of the fork steerer to which the handlebar stem is clamped shall not be threaded.</p> <p>The dimension g shall also ensure that the proper adjustment of the steering system can be achieved.</p> <p>For aluminium and composite fork steerer any internal device that could damage the internal surface of the fork steerer shall be avoided.</p>  <p>Key <i>g</i> distance between the upper, clamping part of the handlebar stem and the upper, part of the fork steerer 1 handlebar stem 2 fork steerer 3 spacer-rings 4 head set 5 head-tube</p>		P
4.3.6.5	Steering stability		P
	The steering shall be free to turn through at least 60° either side of the straight-ahead position and shall exhibit no tight spots, stiffness or slackness in the bearings when correctly adjusted.	>60°	P
	A minimum of 25 % of the total mass of EPAC and rider shall act on the front wheel when the rider is holding the handlebar grips and sitting on the saddle, with the saddle and rider in their most rearward positions.		P
4.3.6.6	Steering assembly – Static strength and safety tests		P
4.3.6.6.1	Handlebar and stem assembly – Lateral bending test		P
4.3.6.6.1.1	General		P
	This test is for manufacturers who produce handlebars and stems or for cycle manufacturers.		P

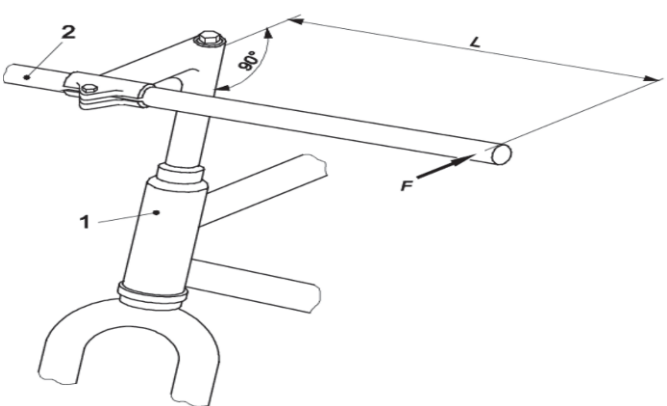
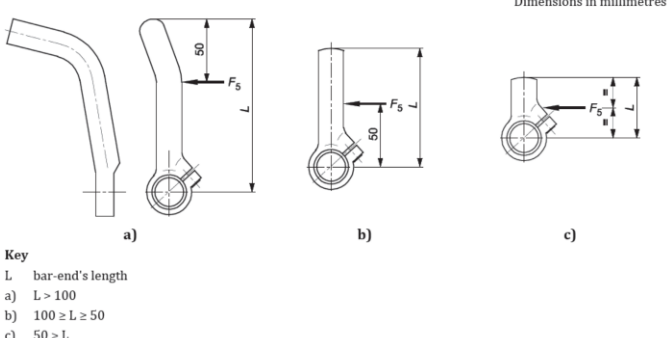


4.3.6.6.1.2	Requirement		P		
	<p>When tested by the method described in 4.3.6.6.1.3, there shall be no cracking or fracture of the handlebar, stem or clamp-bolt and the permanent deformation measured at the point of application of the test force shall not exceed 15 mm.</p> <p>Table 3 — Force on handlebar</p> <table border="1" data-bbox="347 533 810 609"> <tr> <td>Force, F_2</td> <td>800 N</td> </tr> </table>  <p>Figure 12 — Handlebar and stem assembly: lateral bending test</p>	Force, F_2	800 N	<p>800N 1min</p> <p>No cracking or fracture of the handlebar found after the test</p>	P
Force, F_2	800 N				
4.3.6.6.2	Handlebar-stem – Forward bending test		P		
4.3.6.6.2.1	General		P		
	Conduct the test in two stages on the same assembly as follows.		P		
4.3.6.6.2.2	Requirement for Stage 1		P		
	When tested by the method described in 4.3.6.6.2.3, there shall be no visible cracks or fractures and the permanent deformation measured at the point of application of the test force and in the direction of the test force shall not exceed 10 mm.	No visible cracks, fractures or permanent deformation found after the test	P		



	<p>a) Stem extension</p> <p>b) Combined stem and quill</p> <p>c) One piece stem-handlebar</p> <p>Key 1 clamping fixture 2 solid steel bar 3 minimum insertion depth</p>				
4.3.6.6.2.4	Requirement for Stage 2		P		
	<p>When tested by the method described in 4.3.6.6.2.5, there shall be no visible cracks or fractures.</p> <p>Table 4 — Forces on stems</p> <table border="1" data-bbox="343 1093 810 1169"> <tr> <td>Force, F_4</td> <td>2 600 N</td> </tr> </table>	Force, F_4	2 600 N	No visible cracks or fractures found after the test	P
Force, F_4	2 600 N				
4.3.6.6.3	Handlebar to handlebar-stem – Torsional safety test		P		
4.3.6.6.3.1	Requirement		P		
	<p>When tested by the method described in 4.3.6.6.3.2, there shall be no movement of the handlebar relative to the handlebar-stem.</p> <p>Table 5 — Torque on handlebar</p> <table border="1" data-bbox="512 1406 831 1460"> <tr> <td>Torque, T_1</td> <td>70 Nm</td> </tr> </table>	Torque, T_1	70 Nm	No movement of the handlebar relative to the handlebar-stem found after the test	P
Torque, T_1	70 Nm				
4.3.6.6.4	Handlebar-stem to fork steerer – Torsional safety test		P		
4.3.6.6.4.1	Requirement		P		
	When tested by the method described in 4.3.6.6.4.2, there shall be no movement of the handlebar-stem relative to the fork steerer.	No movement of the handlebar-stem relative to the fork	P		



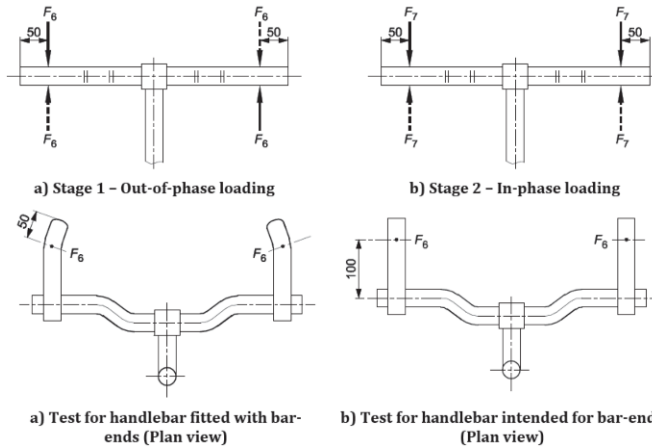
	<p>Table 6 — Torque on handlebar-stem</p> <table border="1" style="margin-left: auto; margin-right: auto;"> <tr> <td>Torque, T_2</td> <td>40 Nm</td> </tr> </table> 	Torque, T_2	40 Nm	<p>steerer found after the test</p>	
Torque, T_2	40 Nm				
<p>4.3.6.6.5</p>	<p>Bar-end to handlebar – Torsional safety test</p>		<p>P</p>		
<p>4.3.6.6.5.1</p>	<p>Requirement</p>		<p>P</p>		
	<p>When tested by the method described in 4.3.6.6.5.2, there shall be no movement of the bar-end in relation to the handlebar.</p> <p>Table 7 — Forces on bar-end</p> <table border="1" style="margin-left: auto; margin-right: auto;"> <tr> <td>Force, F_5</td> <td>300 N</td> </tr> </table>  <p style="text-align: center;">Figure 16 — Bar-end to handlebar: torsional safety test</p>	Force, F_5	300 N	<p>300N 1min</p> <p>No movement of the bar-end in relation to the handlebar found after the test</p>	<p>P</p>
Force, F_5	300 N				
<p>4.3.6.7</p>	<p>Handlebar and stem assembly – Fatigue test</p>		<p>P</p>		
<p>4.3.6.7.1</p>	<p>General</p>		<p>P</p>		
	<p>Handlebar-stems can influence test failures of handlebars and for this reason, a handlebar shall always be tested mounted in a stem, but it is permitted to test a stem with a solid bar in place of the handlebar and bar-ends with dimensions corresponding to handlebars/bar-ends suitable for that stem.</p>		<p>P</p>		
	<p>When the fatigue test is for the stem only, the manufacturer of the stem shall specify the types and sizes of handlebar for which the stem is intended and the test shall be based on the most severe combination.</p>		<p>P</p>		
	<p>Conduct the test in two stages on the same assembly.</p>		<p>P</p>		
<p>4.3.6.7.2</p>	<p>Requirement for Stage 1 and Stage 2</p>		<p>P</p>		
	<p>When tested by the method described in 4.3.6.7.3 or 4.3.6.7.4, there shall be no visible cracks or fractures in any part of the handlebar and stem assembly or any bolt failure.</p>	<p>no visible cracks, fractures or any bolt failure found afeter the test</p>	<p>P</p>		
	<p>For composite handlebars or stems, the running</p>		<p>P</p>		



displacements (peak-to-peak value) at the points where the test forces are applied shall not increase by more than 20 % of the initial values.

Table 8 — Forces on handlebars and bar-ends

Stage 1	Force, F_6	220 N
Stage 2	Force, F_7	280 N

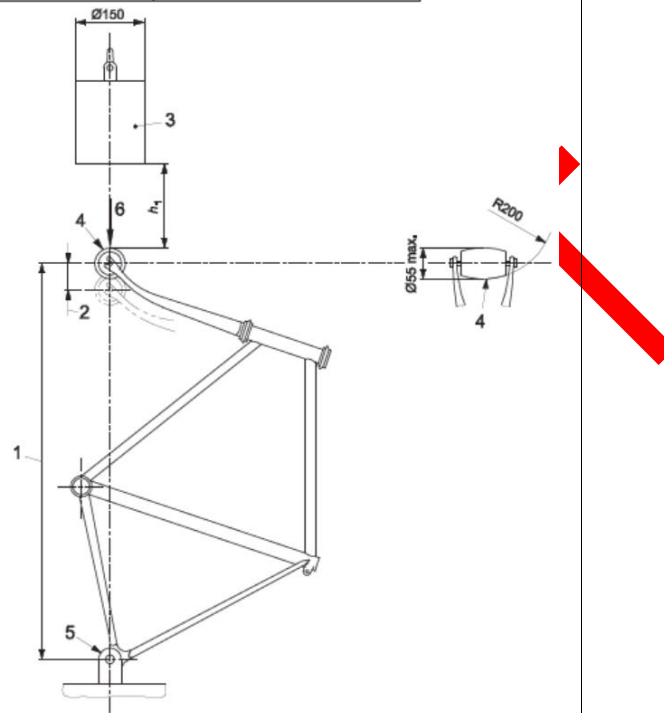


4.3.7	Frames		P						
4.3.7.1	Suspension-frames – Special requirement		P						
	The design shall be such that if the spring or damper fails, neither the tyre shall contact any part of the frame nor the assembly carrying the rear wheel become detached from the rest of the frame.	No such hazards	P						
4.3.7.2	Frame – Impact test (falling mass)		P						
4.3.7.2.1	Requirements		P						
	When tested by the method described in 4.3.7.2.3, there shall be no visible cracks or fractures of the frame.	No visible cracks, fractures of the frame found during the test	P						
	The permanent deformation measured between the axes of the wheel axles shall not exceed the following values: a) 30 mm where a fork is fitted; b) where a dummy fork is fitted in place of a fork, the values are given in Table 9.		P						
	Table 9 — The values of permanent deformation								
	<table border="1"> <thead> <tr> <th>Fork type</th> <th>Real fork</th> <th>Dummy fork</th> </tr> </thead> <tbody> <tr> <td>Permanent deformation</td> <td>30 mm</td> <td>10 mm</td> </tr> </tbody> </table>	Fork type	Real fork	Dummy fork	Permanent deformation	30 mm	10 mm		
Fork type	Real fork	Dummy fork							
Permanent deformation	30 mm	10 mm							
4.3.7.2.2	General		P						
	Manufacturers of frames are permitted to conduct the test with a dummy fork (see Annex E) fitted in place of a front fork.		P						
	Where a frame is convertible for male and female riders by the removal of a bar, test it with the bar removed.		P						
	Where a suspension fork is fitted, test the assembly with the fork extended to its unloaded free length. Where a	A suspension fork is fitted	P						

rear suspension system is incorporated in the frame, secure the suspension in a position equivalent to that which would occur with a 90 kg rider seated on the bicycle. If the type of suspension system does not permit it to be locked, then replace the spring/damper unit by a solid link of the appropriate size and with end fittings similar to those of the spring/damper unit.

Table 10 — Drop heights

Drop height, h_1	360 mm
--------------------	--------



- Key**
- h_1 drop height
 - 1 wheelbase
 - 2 permanent deformation
 - 3 22.5 kg striker
 - 4 low mass roller (1 kg max.)
 - 5 rigid mounting for rear axle attachment point
 - 6 direction of rearward impact

4.3.7.3	Frame and front fork assembly – Impact test (falling frame)		P
4.3.7.3.1	General		P
	Manufacturers of complete EPACs shall conduct the test with the frame fitted with the appropriate front fork.		P
	Where a frame is convertible for male and female riders by the removal of a bar, test it with the bar removed.		P
	Where a suspension fork is fitted, it shall be at its unloaded length prior to the impact. If the spring damper unit can be locked, it shall be locked in its unloaded length position. If the spring/damper cannot be locked, use one of the two following alternative procedures: a) secure the fork at its extended length by an external locking method, or b) replace the fork by a rigid fork which is known to meet the requirements of the impact test described in 4.3.8.5		P

	and of a length which is consistent with an 90 kg rider seated in a normal riding position on the bicycle when it is equipped with the suspension fork.												
	Where a rear suspension system is incorporated in the frame, secure the spring/damper unit in a position equivalent to that which would occur with an 90 kg rider seated on the bicycle; if the type of suspension system does not permit it to be locked, then replace the spring/damper unit by a solid link of the appropriate size and with end fittings similar to those of the spring/damper unit.		P										
4.3.7.3.2	Requirement		P										
	<p>When tested by the method described in 4.3.7.3.3, there shall be no visible cracks or fractures in the assembly and after the second impact there shall be no separation of any parts of any suspension system. The permanent deformation measured between the axes of the wheel axles shall not exceed the values specified in Table 11</p> <p>Table 11 — The values of permanent deformation</p> <table border="1" style="margin-left: auto; margin-right: auto;"> <tr> <td>Permanent deformation</td> <td>60 mm</td> </tr> </table> <p>Table 12 — Drop heights and distribution of masses at seat post, steering head, and bottom bracket</p> <table border="1" style="margin-left: auto; margin-right: auto;"> <tr> <td>Mass 1 Seat-post, M_1 kg</td> <td>30</td> </tr> <tr> <td>Mass 2 Steering head, M_2 kg</td> <td>10</td> </tr> <tr> <td>Mass 3 Bottom bracket, M_3 kg</td> <td>50</td> </tr> <tr> <td>Drop height, h_2 mm</td> <td>300</td> </tr> </table> <p>Key</p> <ul style="list-style-type: none"> 1 wheelbase 2 permanent deformation 3 mass 1 (M_1) 4 mass 2 (M_2) 5 mass 3 (M_3) 6 rigid mounting for rear-axle attachment point 7 steel anvil D distance to the centre of gravity (75 mm) h_2 drop height 	Permanent deformation	60 mm	Mass 1 Seat-post, M_1 kg	30	Mass 2 Steering head, M_2 kg	10	Mass 3 Bottom bracket, M_3 kg	50	Drop height, h_2 mm	300	<p>No visible cracks, fractures or separation of any parts found after the test</p>	P
Permanent deformation	60 mm												
Mass 1 Seat-post, M_1 kg	30												
Mass 2 Steering head, M_2 kg	10												
Mass 3 Bottom bracket, M_3 kg	50												
Drop height, h_2 mm	300												
4.3.7.4	Frame – Fatigue test with pedalling forces		P										
4.3.7.4.1	General		P										



	All types of frame shall be subjected to this test.		P		
	In tests on suspension-frames with pivoted joints, adjust the spring, air-pressure, or damper to provide maximum resistance, or, for a pneumatic damper in which the air-pressure cannot be adjusted, replace the suspension-unit with a rigid link, ensuring that its end fixings and lateral rigidity accurately simulate those of the original unit. For suspension-frames in which the chain-stays do not have pivots but rely on flexing, ensure that any dampers are set to provide the minimum resistance in order to ensure adequate testing of the frame.	No visible cracks, fractures or separation of any parts found after the test	P		
	Where a suspension-frame has adjustable brackets or linkages to vary the resistance of the bicycle against the ground-contact forces or to vary the attitude of the bicycle, arrange the positions of these adjustable components to ensure maximum forces in the frame.		P		
4.3.7.4.2	Requirement		P		
	When tested by the method described in 4.3.7.4.3, there shall be no visible cracks or fractures in any part of the frame, and there shall be no separation of any parts of the suspension system.		P		
	For composite frames, the running displacements (peak-to-peak values) at the points where the test forces are applied shall not increase by more than 20 % of the initial values (see 4.3.1.6).		P		
	<p>Table 13 — Forces on pedal-spindle</p> <table border="1"> <tr> <td>Force, F_7</td> <td>1 000 N</td> </tr> </table> <p>Dimensions in millimetres</p> <p>Key</p> <ul style="list-style-type: none"> R_w height of rigid mount and vertical link R_c length of vertical arm (75 mm) L length of crank replacement (175 mm) 1 rigid mount 2 vertical link 3 ball-joint 5 vertical arm 6 tie-rod 7 centre-line of tie-rod 	Force, F_7	1 000 N		P
Force, F_7	1 000 N				
4.3.7.5	Frame – Fatigue test with horizontal forces		P		
4.3.7.5.1	General		P		
	Where a frame is convertible for male and female riders by the removal of a bar, remove the bar.		P		
	It is not necessary for a genuine fork to be fitted, provided that any substitute fork is of the same length as the intended fork (see Annex F) and it is correctly installed in the steering-head bearings. For a suspension fork, lock it at a length equivalent to that with an 90 kg rider seated on the bicycle either by adjusting the spring/damper or by external means.		P		

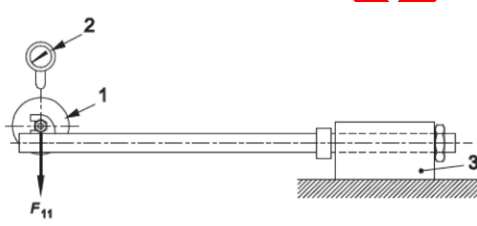


	In tests on suspension frames with pivoted joints, lock the moving part of the frame into a position as would occur with a 90 kg rider seated on the bicycle. This may be achieved by locking the suspension unit in an appropriate position or, if the type of suspension system does not permit it to be locked, then the suspension system may be replaced by a solid link of the appropriate compressed size. Ensure that the axes of the front and rear axles are horizontally in line, as shown in Figure 22. For suspension-frames in which the chain-stays do not have pivots but rely on flexing, ensure that any dampers are set to provide the minimum resistance in order to ensure adequate testing of the frame.		P												
	Where a suspension frame has adjustable brackets or linkages to vary the resistance of the bicycle against the ground-contact forces or to vary the attitude of the bicycle, arrange the positions of these adjustable components to ensure maximum forces in the frame.		P												
4.3.7.5.2	Requirement		P												
	When tested by the method described in 4.3.7.5.3, there shall be no visible cracks or fractures in the frame and there shall be no separation of any parts of any suspension system.	No visible cracks, fractures or separation of any parts found after the test	P												
	<p>For composite frames, the running displacement (peak-to-peak value) at the point where the test forces are applied shall not increase by more than 20 % of the initial values (see 4.3.1.6).</p> <p>Table 14 — Forces and cycles on front fork drop-outs</p> <table border="1"> <thead> <tr> <th>EPAC</th> <th>Front wheel driven EPAC</th> <th>Other driving systems</th> </tr> </thead> <tbody> <tr> <td>Forward force, F_8 N</td> <td>600</td> <td>500</td> </tr> <tr> <td>Rearward force, F_9 N</td> <td>600</td> <td>500</td> </tr> <tr> <td>Test cycles, C_1</td> <td>100 000</td> <td>100 000</td> </tr> </tbody> </table> <p>Key 1 free-running guided roller 2 rigid, pivoted mounting for rear axle attachment point</p>	EPAC	Front wheel driven EPAC	Other driving systems	Forward force, F_8 N	600	500	Rearward force, F_9 N	600	500	Test cycles, C_1	100 000	100 000		P
EPAC	Front wheel driven EPAC	Other driving systems													
Forward force, F_8 N	600	500													
Rearward force, F_9 N	600	500													
Test cycles, C_1	100 000	100 000													
4.3.7.6	Frame – Fatigue test with a vertical force		P												
4.3.7.6.1	General		P												
	Where a frame is convertible for male and female riders		P												



	by the removal of a bar, remove the bar.				
	Where a suspension frame has adjustable brackets or linkages to vary the resistance of the bicycle against the ground-contact forces or to vary the attitude of the bicycle, arrange the positions of these adjustable components to ensure maximum forces in the frame. Secure the rear suspension as described in 4.3.7.4.1.		P		
	If a suspension fork is fitted lock it at a length equivalent to that with an 90 kg rider seated on the bicycle either by adjusting the spring/damper or by external means.		P		
4.3.7.6.2	Requirement		P		
	When tested by the method described in 4.3.7.6.3, there shall be no visible cracks or fractures in the frame and there shall be no separation of any parts of the suspension system.	No visible cracks, fractures or separation of any parts found after the test	P		
	<p>For composite frames, the running displacement (peak-to-peak value) at the point where the test forces are applied shall not increase by more than 20 % of the initial value (see 4.3.1.6).</p> <p>Table 15 — Forces on seat-stem</p> <table border="1" style="margin-left: 20px;"> <tr> <td>Force, F_{10}</td> <td>1 100 N</td> </tr> </table> <p>Key</p> <ul style="list-style-type: none"> E horizontal, rearward extension H position equivalent to that of the centre of the saddle-clamp with the bicycle 1 free-running roller 2 steel bar 3 locked suspension unit or solid link for pivoted chain-stays 4 rigid, pivoted mounting for rear axle attachment point 	Force, F_{10}	1 100 N		P
Force, F_{10}	1 100 N				
4.3.8	Front fork		P		
4.3.8.1	General		P		
	4.3.8.2, 4.3.8.4, 4.3.8.5 and 4.3.8.6 apply to all types of fork.		P		
	In the strength tests, 4.3.8.4, 4.3.8.5, 4.3.8.6 and 4.3.8.7, a suspension-fork shall be tested in its free, uncompressed length condition.		P		
4.3.8.2	Means of location of the axle and wheel retention		P		
	The slots or other means of location for the wheel-axle within the front fork shall be such that when the axle or cones are firmly abutting the top face of the slots, the front wheel remains central within the fork.		P		
	The front fork and wheel shall also fulfil the requirements of 4.3.9.4 and 4.3.9.5.		P		



4.3.8.3	Suspension-forks – Special requirements	A suspension fork fitted	P		
4.3.8.3.1	Tyre-clearance test		P		
4.3.8.3.1.1	Requirement	No such hazards	P		
	When tested by the method described in 4.3.8.3.1.2, the tyre shall not contact the crown of the fork nor shall the components separate.		P		
4.3.8.3.2	Tensile test		P		
4.3.8.3.2.1	Requirement		P		
	When tested by the method described in 4.3.8.3.2.2, there shall be no detachment or loosening of any parts of the assembly and the tubular, telescopic components of any fork-leg shall not separate under the test force.		P		
4.3.8.4	Front fork – Static bending test		P		
4.3.8.4.1	Requirement		P		
	<p>When tested by the method described in 4.3.8.4.2, there shall be no fractures or visible cracks in any part of the fork, and the permanent deformation, measured as the displacement of the axis of the wheel-axle or simulated axle in relation to the axis of the fork steerer, shall not exceed 10 mm.</p>  <p>Key 1 loading attachment swivel on axle 2 deflection measuring device 3 rigid mount incorporating head bearings</p> <p>Figure 24 — Front fork: static bending test (typical arrangement)</p> <p>Table 16 — Forces on loading attachment</p> <table border="1" data-bbox="399 1433 925 1523"> <tr> <td>Force, F_{11}</td> <td>1 500 N</td> </tr> </table>	Force, F_{11}	1 500 N	<p>No any damage, permanent deformation detachment or loosening of any parts found after the test</p>	P
Force, F_{11}	1 500 N				
4.3.8.5	Front fork – Rearward impact test		P		
4.3.8.5.1	Forks made entirely of metal		P		
4.3.8.5.1.1	Crown/steerer joint assembled by welding or brazing		P		
	When tested by the method described in 4.3.8.5.3, there shall be no fractures or visible cracks in any part of the fork, and the permanent deformation, measured as the displacement of the axis of the wheel-axle or simulated axle in relation to the axis of the fork steerer, shall not exceed 45 mm.		P		
	If the fork is used in the frame impact test (falling-mass), 4.3.7.2, there is no need to perform this test.		P		
4.3.8.5.1.2	Crown/steerer joint assembled by press-fitting, bonding, or clamping		P		
	When tested by the method described 4.3.8.5.4 a), if there are any fractures or visible cracks in any part of the	No any damage, permanent	P		



	<p>fork, and the permanent deformation, measured as the displacement of the axis of the wheel-axle or simulated axle in relation to the axis of the fork steerer, exceeds 45 mm, the fork shall be considered to have failed. If the fork meets these criteria then it shall be subjected to a second test as described in 4.3.8.5.4 b), after which, it shall exhibit no fractures, then it shall be subjected to a third test as described in 4.3.8.5.4 c), irrespective of the amount of permanent deformation, there shall be no relative movement between the steerer and the crown.</p>	<p>deformation found after the test</p>							
<p>4.3.8.5.2</p>	<p>Forks which have composite parts</p>		<p>P</p>						
	<p>When tested by the method described in 4.3.8.5.3, there shall be no fractures in any part of a fork and the permanent deformation, measured as the displacement of the axis of the wheel-axle or simulated axle in relation to the axis of the fork steerer, shall not exceed 45 mm. After which, it shall exhibit no fractures, then it shall be subjected to a second test as described in 4.3.8.5.4 c) Torque on fork, irrespective of the amount of permanent deformation, there shall be no relative movement between the steerer and the crown.</p> <p style="text-align: center;">Table 17 — Drop heights</p> <table border="1" style="margin-left: auto; margin-right: auto;"> <thead> <tr> <th></th> <th>Forks made entirely of metal</th> <th>Forks which have composite parts</th> </tr> </thead> <tbody> <tr> <td>Drop height, h_4</td> <td>360 mm</td> <td>360 mm</td> </tr> </tbody> </table> <div style="text-align: center;"> </div> <p style="text-align: center;">Figure 25 — Front fork: rearward impact test</p> <p style="text-align: center;">Figure 25 — Front fork: rearward impact test</p> <div style="text-align: center;"> </div> <p style="text-align: center;">Figure 26 — Low-mass roller</p>		Forks made entirely of metal	Forks which have composite parts	Drop height, h_4	360 mm	360 mm	<div style="text-align: center; font-size: 2em; color: red; opacity: 0.5;">X</div>	<p style="text-align: center;">P</p>
	Forks made entirely of metal	Forks which have composite parts							
Drop height, h_4	360 mm	360 mm							

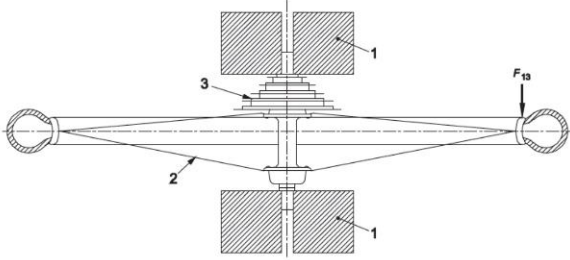
	<p style="text-align: center;">Table 18 — Torque on fork</p> <table border="1" style="margin-left: auto; margin-right: auto;"> <tr> <td>Torque, T_3</td> <td>80</td> </tr> </table> <p style="text-align: right; margin-right: 50px;">Torque in newton metres</p> <p>Key</p> <ul style="list-style-type: none"> 1 front fork 2 fork mounting fixture (Fixture representative of the head-tube) 3 rigid mount 4 test adaptor <p style="text-align: center;">Figure 27 — Fork steerer torsional test (a typical example)</p>	Torque, T_3	80		
Torque, T_3	80				
4.3.8.6	Front fork – Bending fatigue test plus rearward impact test		P		
4.3.8.6.1	Requirement		P		
	When tested by the method described in 4.3.8.6.2, there shall be no fractures in any part of the fork, and the permanent deformation, measured as the displacement of the axis of the wheel-axle or simulated axle in relation to the axis of the fork steerer, shall not exceed 45 mm.	No any damage, fractures or permanent deformation found after the test	P		
	<p>For composite forks, the running displacement (peak-to-peak value) at the points where the test forces are applied shall not increase by more than 20 % of the initial values (see 4.3.1.6).</p> <p style="text-align: center;">Table 19 — Forces on loading attachment</p> <table border="1" style="margin-left: auto; margin-right: auto;"> <tr> <td>Force, F_{12}</td> <td>± 500 N</td> </tr> </table> <p>Key</p> <ul style="list-style-type: none"> 1 pivoted force attachment 2 rigid mount incorporating head bearings <p style="text-align: center;">Figure 28 — Front fork: bending fatigue test</p>	Force, F_{12}	± 500 N		P
Force, F_{12}	± 500 N				
4.3.8.7	Forks intended for use with hub- or disc-brakes		P		
4.3.8.7.1	General		P		
	When a fork is intended for use with a hub- or disc-brake and whether supplied as original equipment or as an accessory, the fork manufacturer shall provide an attachment point on the fork-blade for the torque-arm or calliper.		P		
	In tests conducted by the methods described in 4.3.8.7.3 and 4.3.8.7.5 and where more than one mounting-point is provided for a hub- or disc-brake, the following shall		P		



	<p>apply:</p> <p>a) Where a complete EPAC is supplied, the test adaptor shall be secured to the mounting-point used on EPAC. If bracket is supplied, it shall be used to perform the test;</p> <p>b) Where a fork is supplied as an accessory with more than one mounting-point, separate tests shall be conducted on each of the mounting-points on separate forks.</p>												
4.3.8.7.2	Static brake-torque test		P										
	When tested by the method described in 4.3.8.7.3, there shall be no fractures or visible cracks in any part of the fork.	No visible cracks found after the test	P										
4.3.8.7.3	Fork for hub/disc-brake – Static brake-torque test		P										
	Mount the fork in a fixture representative of the head-tube according to Annex G and gripped in the normal head-bearings, fit an axle to the fork, and mount on the axle a pivoted, straight adaptor as shown in Figure 29 to provide a torque-arm of L ₂ in length (see Table 20) and a suitable attachment for the brake mounting-point. If the wheel size is not listed in Table 20, the length L ₂ shall be equal to one half of the wheel diameter.		P										
	<p>Apply a rearward force of 1 000 N to the torque arm perpendicular to the fork steerer axis and in the plane of the wheel. Maintain this force for 1 min, then reduce the force to 100 N and record any permanent deformation.</p> <p style="text-align: center;">Table 20 — Fixture length</p> <p style="text-align: right;">Dimensions in mill</p> <table border="1" style="margin-left: auto; margin-right: auto;"> <thead> <tr> <th>Wheel diameter</th> <th>24"</th> <th>26"</th> <th>650b</th> <th>29" or 700c</th> </tr> </thead> <tbody> <tr> <td>Arm Length, L₂</td> <td>305</td> <td>330</td> <td>349</td> <td>368</td> </tr> </tbody> </table> <p>Key</p> <p>1 rigid mount incorporating head bearings 2 brake mounting-point 3 test adaptor</p>	Wheel diameter	24"	26"	650b	29" or 700c	Arm Length, L ₂	305	330	349	368		P
Wheel diameter	24"	26"	650b	29" or 700c									
Arm Length, L ₂	305	330	349	368									
4.3.8.7.4	Fork for hub/disc-brake – Brake mount fatigue test		P										
	When tested by the method described in 4.3.8.7.5, there shall be no fractures or visible cracks in any part of the fork and, in the case of suspension-forks, there shall be no separation of any parts	No damage or separation of any parts found after the test	P										
4.3.8.7.5	Fork for hub/disc-brake – Brake mount fatigue test		P										
	Mount the fork in a fixture representative of the head-tube according to Annex G and gripped in the normal head-bearings, fit an axle to the fork, and mount on the axle a pivoted, straight adaptor as shown in Figure 30 to provide a torque-arm of L ₂ in length (see Table 21) and a suitable attachment for the brake mounting-point.		P										
	Apply repeated, horizontal, dynamic forces of 600 N rearward to the end of the torque-arm parallel to the plane of the wheel (as shown in Figure 30) for C2 cycles (see Table 21). The maximum test frequency shall be maintained as specified in 4.3.1.6.		P										

	<p style="text-align: center;">Table 21 — Minimum test cycles</p> <table border="1" style="margin: auto;"> <tr> <td>Test cycles, C_2</td> <td>12 000</td> </tr> </table> <p>Key</p> <ul style="list-style-type: none"> 1 rigid mount incorporating head bearings 2 brake mounting-point 3 test adaptor <p style="text-align: center;">Figure 30 — Fork for hub/disc-brake: Brake mount fatigue test</p>	Test cycles, C_2	12 000						
Test cycles, C_2	12 000								
4.3.8.8	Tensile test for a non-welded fork	Not non-welded fork	P						
4.3.8.8.1	General		P						
	This test is for forks where the blades and/or the fork steerer are secured in the fork-crown by press-fitting, clamping, adhesives, or any method other than brazing or welding.		P						
4.3.8.8.2	Requirement		P						
	When tested by the method described in 4.3.8.8.3, there shall be no detachment or loosening of any parts of the assembly.		P						
4.3.9	Wheels and wheel/tyre assembly		P						
4.3.9.1	Wheels/tyre assembly – Concentricity tolerance and lateral tolerance		P						
4.3.9.1.1	Requirements		P						
	<p>When measured by the method described in 4.3.9.1.2, the run-out shall not exceed the values which are given in Table 22.</p> <p style="text-align: center;">Table 22 — Wheel/tyre assembly - Concentricity and lateral tolerance</p> <p style="text-align: center;"><small>Dimensions in millimetres</small></p> <table border="1" style="margin: auto;"> <thead> <tr> <th></th> <th>Intended for rim-brakes</th> <th>Not intended for rim-brakes</th> </tr> </thead> <tbody> <tr> <td>Concentricity and lateral tolerance</td> <td style="text-align: center;">1</td> <td style="text-align: center;">2</td> </tr> </tbody> </table> <p style="text-align: center;">a) Rim with tyre b) Rim without tyre</p> <p>Key</p> <ul style="list-style-type: none"> 1 dial-gauge (concentricity) 2 instrument stand 3 hub axle support 4 dial-gauge (lateral run-out) 5 instrument stand 6 roller indicator 7 rim with tyre 8 rim without tyre 9 dial-gauge (concentricity) (alternative position) 10 instrument stand 		Intended for rim-brakes	Not intended for rim-brakes	Concentricity and lateral tolerance	1	2		P
	Intended for rim-brakes	Not intended for rim-brakes							
Concentricity and lateral tolerance	1	2							



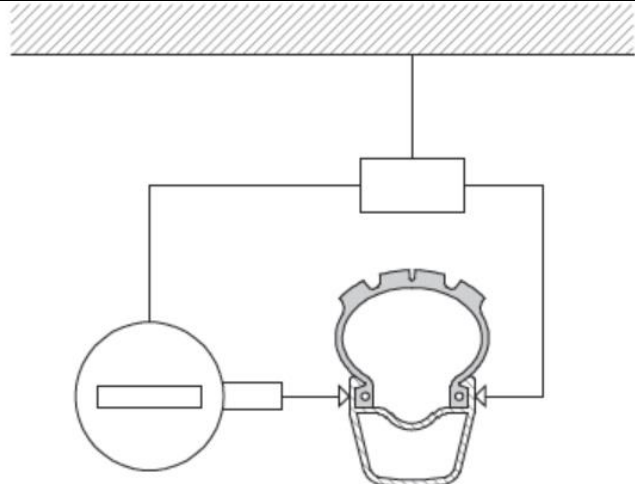
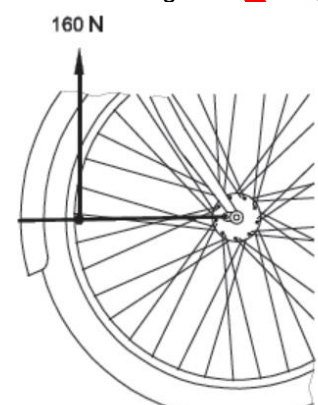
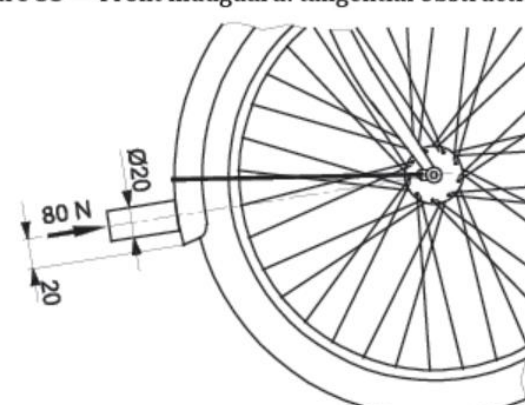
4.3.9.2	Wheel/tyre assembly – Clearance		P				
	<p>Alignment of the wheel assembly in EPAC shall allow not less than the clearance values given in Table 23 between the tyre and any frame or fork element or a front mudguard and its attachment bolts.</p> <p>Table 23 — Wheel/tyre assembly - Clearance</p> <table border="1" data-bbox="416 533 815 622"> <tr> <td>Clearance</td> <td>6</td> </tr> </table>	Clearance	6	7.8mm	P		
Clearance	6						
4.3.9.3	Wheel/tyre assembly – Static strength test		P				
4.3.9.3.1	Requirement		P				
	<p>When a fully assembled wheel fitted with a tyre inflated to the maximum inflation pressure is tested by the method described in 4.3.9.3.2, there shall be no failure of any of the components of the wheel, and the permanent deformation, measured at the point of application of the force on the rim, shall not exceed the values which are given in Table 24.</p> <p>Table 24 — The values of permanent deformation</p> <table border="1" data-bbox="432 1010 815 1099"> <tr> <td>Permanent deformation</td> <td>1,5</td> </tr> </table> <p>Table 25 — Forces on rim</p> <table border="1" data-bbox="352 1167 743 1234"> <tr> <td>Force, F_{13}</td> <td>250</td> </tr> </table>  <p>Key 1 clamping fixture 2 wheel/tyre assembly 3 drive sprockets</p> <p>Figure 32 — Wheel/tyre assembly: static strength test</p>	Permanent deformation	1,5	Force, F_{13}	250	No failure found during the test	P
Permanent deformation	1,5						
Force, F_{13}	250						
4.3.9.4	Wheels – Wheel retention		P				
4.3.9.4.1	General		P				
	Wheel retention safety is related to the combination of wheel, retention device, and drop-out design.		P				
	Wheels shall be secured to EPAC frame and fork such that when adjusted to the manufacturer's instructions they comply with 4.3.9.4.2, 4.3.9.4.3 and 4.3.9.5.		P				
	Wheel nuts shall have a minimum removal torque of 70 % of the manufacturer's recommended tightening torque.		P				
	Where quick-release axle devices are used they shall comply with 4.3.9.5.		P				
4.3.9.4.2	Wheel retention – Retention devices secured		P				



4.3.9.4.2.1	Requirement		P
	When tested by the method described in 4.3.9.4.2.2, there shall be no relative motion between the axle and the front fork/frame.	No relative motion after the test	P
4.3.9.5	Wheels – Quick-release devices – Operating features		P
	Any quick-release device shall have the following operating features: a) it shall be adjustable to allow setting for tightness; b) its form and marking shall clearly indicate whether the device is in the open or locked position; c) if adjustable by a lever, the force required to close a properly set lever shall not exceed 200 N and, at this closing force there shall be no permanent deformation of the quick-release device; d) the releasing force of the clamping device when closed shall not be less than 50 N; e) if operated by a lever, the quick-release device shall withstand without fracture or permanent deformation a closing force of not less than 250 N applied with the adjustment set to prevent closure at this force; f) the wheel retention with the quick-release device in the clamped position shall be in accordance with 4.3.9.4.2, 4.3.9.4.3; g) the front wheel retention with the quick-release device in the open position shall be in accordance with 4.3.9.4.3.		P
	If applied to a lever, the forces specified in c), d), and e) shall be applied 5 mm from the tip end of the lever.		P
4.3.10	Rims, tyres and tubes		P
4.3.10.1	General		P
	Non-pneumatic tyres are excluded from the requirements of 4.3.10.2 and 4.3.10.3.		P
4.3.10.2	Tyre inflation pressure		P
	The maximum inflation pressure recommended by the manufacturer shall be permanently marked on the side wall of the tyre so as to be readily visible when the latter is assembled on the wheel. If the rim manufacturer recommends a maximum tyre inflation pressure, it shall be clearly and permanently marked on the rim and also specified in the manufacturer's instructions.		P
	It is recommended that the minimum inflation pressure specified by the tyre manufacturer also be permanently marked on the side wall of the tyre.		P
4.3.10.3	Tyre and rim compatibility		P
	Tyres that comply with the requirements of ISO 5775-1 and rims that comply with the requirements of ISO 5775-2 are compatible. The tyre, tube and tape shall be compatible with the rim design. When inflated to 110 % of the maximum inflation pressure, determined by the lower value between maximum inflation pressures recommended on the rim or the tyre, for a period of not less than 5 min, the tyre shall remain intact on the rim.	7min The tyre remains intact on the rim	P
4.3.10.4	Rim-wear		P
	In the case where the rim forms part of a braking system	Durable and legible	P



	and there is a danger of failure due to wear, the manufacturer shall make the rider aware of this danger by durable and legible marking on the rim, in an area not obscured by the tyre, (see also Clause 6 z) and 5.1).	marking marked on the rim	
	Where the rim is made of composite materials, the manufacturer shall include in the manufacturer's instructions warnings of the danger of rim failure caused by wear of the braking surfaces.		P
4.3.10.5	Greenhouse effect test for composite wheels		P
4.3.10.5.1	General		P
	This requirement is to ensure wheels made from composite materials that are subjected to high temperature conditions (i.e. such as car storage in direct sunlight) do not suffer concealed damage that could subsequently affect the safety performance of the wheel during normal use.		P
4.3.10.5.2	Requirement		P
	<p>When a fully assembled wheel made of composite material, fitted with the appropriate size tyre and inflated according to the lowest value between maximum inflation pressure recommended on the rim or the tyre, is tested by the method described as 4.3.10.5.3, there shall be:</p> <ul style="list-style-type: none"> — no failure of any of the components of the wheel; — no tyre separation from the rim during the test; — no increase in rim width greater than 5 % of the initial maximal width value; — compliance of lateral and concentricity tolerance according to 4.3.9.1; — compliance of tyre and rim compatibility according to 4.3.10.3; — compliance of static strength according to 4.3.9.3. 	Has complied with	P
	<p style="text-align: center;">Figure 33 — Wheel laid down on tyre and axle</p>		

	 <p>Figure 34 — Maximum rim's width measuring</p>		
<p>4.3.11</p>	<p>Front mudguard</p>	<p>No Front mudguard fitted</p>	<p>N</p>
<p>4.3.11.1</p>	<p>Requirements</p>		<p>N</p>
	<p>If front mudguard is fitted, when tested by the method described in the two-stage tests in 4.3.11.2 (for mudguard with stays) or 4.3.11.3 (for mudguard without stays), the front mudguard shall not prevent rotation of the wheel or obstruct steering.</p>  <p>Figure 35 — Front mudguard: tangential obstruction test</p>  <p>Figure 36 — Front mudguard: radial force test</p>		<p>N</p>



4.3.12	Pedals and pedal/crank drive system		P											
4.3.12.1	Pedal tread		P											
	The tread surface of a pedal shall be secured against movement within the pedal assembly.		P											
4.3.12.1.2	Toe Clips		P											
	Pedals intended to be used without toe-clips, or for optional use with toe-clips, shall have: a) tread surfaces on the top and bottom surfaces of the pedal; or b) a definite preferred position that automatically presents the tread surface to the rider's foot.		P											
	Pedals designed to be used only with toe-clips or shoe-retention devices shall have toe-clips or shoe-retention devices securely attached and need not comply with the requirements of 4.3.12.1.2 a) and b).	No toe-clips	P											
4.3.12.2	Pedal clearance		P											
4.3.12.2.1	Ground clearance		P											
	With EPAC un-laden, the pedal at its lowest point and the tread surface of the pedal parallel to the ground and uppermost where it has only one tread surface, EPAC shall be capable of being leaned over at an angle of θ from the vertical before any part of the pedal touches the ground. The values are given in Table 26.	No hazards	P											
	When EPAC is equipped with a suspension system, this measurement shall be taken with the suspension adjusted to the softest condition and with EPAC depressed into a position such as would be caused by a rider weighing 90 kg.		P											
	<p>Table 26 — The values of ground clearance</p> <table border="1" style="margin-left: auto; margin-right: auto;"> <tr> <td style="padding: 5px;">Lean angle θ</td> <td style="padding: 5px;">25</td> </tr> </table>	Lean angle θ	25		P									
Lean angle θ	25													
4.3.12.2.2	Toe clearance		P											
	<p>EPACs shall have at least C clearance between the pedal and front tyre or mudguard (when turned to any position). The clearance shall be measured forward and parallel to the longitudinal axis of EPAC from the centre of either pedal-axle to the arc swept by the tyre or mudguard, whichever results in the least clearance (see Figure 37). The values are given in Table 27.</p> <p style="text-align: center;">Table 27 — The values of toe clearance</p> <table border="1" style="margin-left: auto; margin-right: auto;"> <tr> <td colspan="2"></td> <td style="text-align: right; padding-right: 5px;">Dime1</td> </tr> <tr> <td rowspan="2" style="padding: 5px;">Toe clearance C</td> <td style="padding: 5px;">without foot retention</td> <td style="padding: 5px;">100</td> </tr> <tr> <td style="padding: 5px;">with foot retention</td> <td style="padding: 5px;">89</td> </tr> <tr> <td colspan="3" style="padding: 5px;">NOTE Foot retention system, e.g. quick-release pedal or toe-clip.</td> </tr> </table>			Dime1	Toe clearance C	without foot retention	100	with foot retention	89	NOTE Foot retention system, e.g. quick-release pedal or toe-clip.			<p>95mm</p> <p>No such hazards</p>	P
		Dime1												
Toe clearance C	without foot retention	100												
	with foot retention	89												
NOTE Foot retention system, e.g. quick-release pedal or toe-clip.														



	<p>Key <i>c</i> clearance 1 longitudinal axis 2 front tyre 3 mudguard 4 pedal</p> <p>Figure 37 — Pedal to wheel/mudguard: toe clearance</p>				
4.3.12.3	Pedal – Static strength test		P		
4.3.12.3.1	Requirement		P		
	<p>When tested by the method described in 4.3.12.3.2, there shall be no fractures, visible cracks, or distortion of the pedal or spindle that could affect the operation of the pedal and pedal-spindle.</p> <p>Table 28 — Forces on pedal</p> <table border="1" data-bbox="352 1084 767 1155"> <tr> <td>Force, F_{14}</td> <td>1500</td> </tr> </table> <p>Key 1 rigid mount</p> <p>Figure 38 — Pedal/pedal-spindle assembly: static strength test</p>	Force, F_{14}	1500	<p>1500N 1min</p> <p>No fractures, visible cracks, or distortion found after the test</p>	P
Force, F_{14}	1500				
4.3.12.4	Pedal – Impact test		P		
4.3.12.4.1	Requirement		P		
	<p>When tested by the method described in 4.3.12.4.2, there shall be no fractures of any part of the pedal body, the pedal-spindle or any failure of the bearing system.</p>	<p>No fractures found after the test</p>	P		

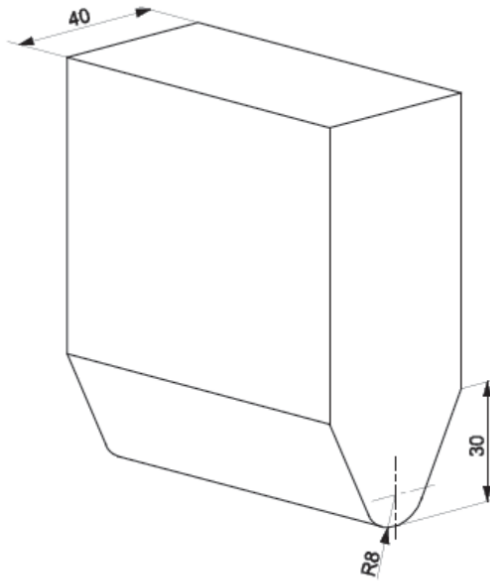


Figure 39 — Striker dimensions

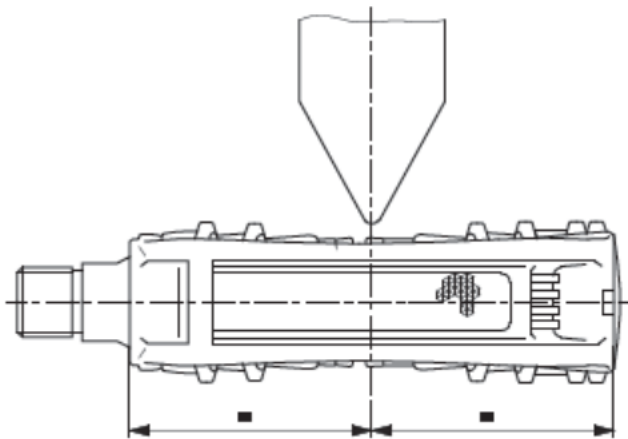
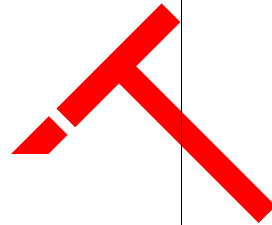


Figure 40 — Position of impact

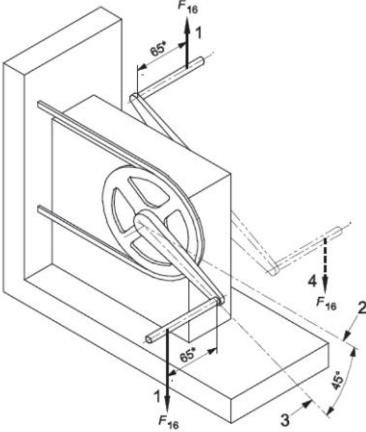



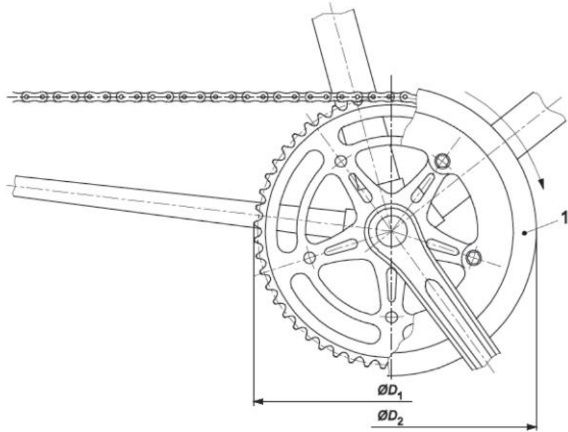
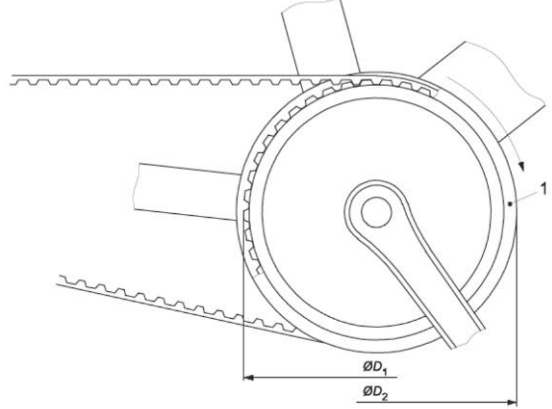
4.3.12.5	Pedal – Dynamic durability test		P
4.3.12.5.1	Requirement		P
	When tested by the method described in 4.3.12.5.2, there shall be no fractures or visible cracking of any part of the pedal, the pedal-spindle nor any failure of the bearing system.	No fractures or visible cracking found after the test	P



	<p style="text-align: center;">Table 29 — Masses on pedal</p> <table border="1" style="margin-left: auto; margin-right: auto;"> <tr> <td>Mass, M_4</td> <td>80</td> </tr> </table> <p style="text-align: center;">Figure 41 — Pedal/pedal-spindle: dynamic durability test</p>	Mass, M_4	80				
Mass, M_4	80						
4.3.12.6	Drive-system – Static strength test		P				
4.3.12.6.1	Requirement		P				
	<p>Drive-system with chain When tested by the method described in 4.3.12.6.2, there shall be no fracture of any component of the drive system, and drive capability shall not be lost.</p>	<p>No fractures found after the test No drive capability lost found during the test</p>	P				
	<p>Drive-system with belt When tested by the method described in 4.3.12.6.3, there shall be no fracture of any component of the drive system, and the belt shall not slip/skip, fracture or cause any loss in drive capability. Smooth sliding between pulleys and belt is allowed at a rate not exceeding 1 %/s at the drive axis.</p>	<p>No this bicycle Chain drive bicycle</p>	P				
4.3.12.7	Crank assembly – Fatigue test		P				
4.3.12.7.1	Requirement		P				
	<p>When tested by the method described in 4.3.12.7.2, there shall be no fractures or visible cracks in the cranks, the bottom-bracket spindle or any of the attachment features, or loosening or detachment of the chain-wheel from the crank.</p>	<p>No fractures or visible cracking found after the test</p>	P				
	<p>For composite cranks, the running displacements (peak-to-peak values) of either crank at the point where the test forces are applied shall not increase by more than 20 % of the initial value (see 4.3.1.6).</p> <p>Table 30 — Forces on pedal-spindle and test cycles</p> <table border="1" style="margin-left: auto; margin-right: auto;"> <tr> <td>Force, F_{16}</td> <td>1 300</td> </tr> <tr> <td>Test cycles, C</td> <td>100 000</td> </tr> </table>	Force, F_{16}	1 300	Test cycles, C	100 000		P
Force, F_{16}	1 300						
Test cycles, C	100 000						



	 <p>Key</p> <ul style="list-style-type: none"> 1 repeated test force 2 horizontal axis 3 axis of crank 4 alternative left crank arrangement from outboard face of crank * from outboard face of crank <p>Figure 42 — Crank assembly: fatigue test with cranks at 45° (typical test arrangement)</p>		
4.3.13	Drive-chain and drive belt		P
4.3.13.1	Drive-chain		P
	<p>Where a chain-drive is used as a means of transmitting the motive force, the chain shall operate over the front and rear sprockets without binding. The chain shall conform to the tensile strength and push-out force requirements of ISO 9633</p>		P
4.3.13.2	Drive belt	Chain drive bicycle	P
4.3.13.2.1	Requirement		P
	<p>Where a belt-drive is used as a means of transmitting the motive force, the drive belt shall operate over the front and rear pulleys without binding. And when tested by the methods described in 4.3.13.2.2, there shall be no evidence of cracking, fracture or delamination of the belt drive.</p> <p>4 000 N is the tension load within the belt and requires a load F_{17} of 8 000 N to achieve this tension</p>  <p>Figure 43 — Drive belt - Tensile strength test</p>		P
4.3.14	Chain-wheel and belt-drive protective device		P
4.3.14.1	Requirement		P
	<p>EPAC shall be equipped with one of the following;</p> <ul style="list-style-type: none"> a) a chain wheel disc or drive pulley disk which conforms to 4.3.14.2; or b) a chain and drive belt protective device which conforms to 4.3.14.3; or c) where fitted with positive foot-retention devices on the pedals, a combined front gear-change guide which conforms to 4.3.14.4 shall be used. 		P
4.3.14.2	Chain-wheel disc and drive pulley disc diameter		P
	A chain-wheel disc shall exceed the diameter of the		P

	<p>outer chain-wheel, when measured across the tips of the teeth by not less than 10 mm (see Figure 44).</p>  <p>Key 1 chain-wheel disc $D_2 \geq D_1 + 10$</p> <p>Figure 44 — Chain-wheel disc</p>		
	<p>A drive pulley disc shall exceed the diameter of the front pulley, when measured across the tips of the teeth by not less than 10 mm (see Figure 45). Where the design is such that the pedal-crank and chain-wheel are too close together to accommodate a full disc, a partial disc may be fitted which closely abuts the pedal-crank.</p>  <p>Key 1 drive pulley disc $D_2 \geq D_1 + 10$</p> <p>Figure 45 — Drive pulley disc</p>		P
4.3.14.3	Chain and drive belt protective device	No Chain protector	N
	<p>A chain protective device shall, as a minimum, shield the side-plates and top surface of the chain and the chain-wheel for a distance of at least 25 mm rearwards along the chain from the point where the chain-wheel teeth first pass between the side-plates of the chain and forwards round the outer chain-wheel to a horizontal line passing through the bottom-bracket axle centre (see Figure 46 a)).</p>		N

	<p>a) A - enlarged (Chain)</p>		
	<p>A drive belt protective device shall, as a minimum, shield the side and top surface of the drive belt and the front pulley for a distance of at least 25 mm rearwards along the drive belt from the point where the tip circle of the pulley is intersected by the tip line of the belt (line C in Figure 46 b)) and forwards round the front pulley to a horizontal line passing through the bottom-bracket axle centre (see Figure 46 b)).</p> <p>b) A - enlarged (Drive belt)</p>		N
4.3.14.4	<p>Combined front gear-change guide</p>		P
	<p>When the chain is located in the outer gear position, some portion of the combined front gear change guide shall be above the chain in the region 25 mm from the point where the chain wheel first passes between the side plates of the chain, parallel to the chain side plates in the direction towards the rear wheel of the bicycle (see Figure 47).</p>		P
	<p>In addition some portion of the combined front gear change guide shall be present below the chain in the region beyond 25 mm from the point where the chain wheel first passes between the side plates of the chain, parallel to the chain side plates in the direction towards the rear wheel of the bicycle (see Figure 47).</p> <p>Key a the point where the chain-wheel first passes between the side-plates of the chain b 25 mm rearwards from the point where the chain-wheel first passes between the side plates of the chain</p> <p>Figure 47 — Chain and chain-wheel junction</p>		P



	It is recommended that the gap between front-gear and front gear-change guide specified by the manufacturer is properly set.		P
4.3.15	Saddles and seat-posts		P
4.3.15.1	Limiting dimensions		P
	No part of the saddle, saddle supports, or accessories to the saddle shall be more than 125 mm above the top saddle surface at the point where the saddle surface is intersected by the seat-post axis.	>125mm	P
4.3.15.2	Seat-post – Insertion-depth mark or positive stop		P
	The seat-post shall be provided with one of the two following alternative means of ensuring a safe insertion-depth into the frame: a) it shall contain a permanent, transverse mark of length not less than the external diameter or the major dimension of the cross-section of the seat-post that clearly indicates the minimum insertion-depth of the seat-post into the frame. For a circular cross-section, the mark shall be located not less than two diameters of the seat-post from the bottom of the seat-post (i.e. where the diameter is the external diameter). For a non-circular cross-section, the insertion-depth mark shall be located not less than 65 mm from the bottom of the seat-post (i.e. where seat-post has its full cross-section); b) it shall incorporate a permanent stop to prevent it from being drawn out of the frame such as to leave the insertion less than the amount specified in a) above.		P
4.3.15.3	Saddle/seat-post – Safety test		P
4.3.15.3.1	General		P
	If a suspension seat-post is involved, the test may be conducted with the suspension-system either free to operate or locked. If it is locked, the pillar shall be at its maximum length.		P
4.3.15.3.2	Saddles with adjustment-clamps		P
	When tested by the method described in 4.3.15.3.4, there shall be no movement of the saddle adjustment clamp in any direction with respect to the seat-post, or of the seat-post with respect to the frame, nor any failure of saddle, adjustment clamp or seat-post. If the saddle design is such that it cannot accurately test the saddle/seat-post clamp, it shall be possible to use a fixture which is representative of the saddle dimensions.	No Saddle adjustment-clamps fitted	P
4.3.15.3.3	Saddles without adjustment-clamps		P
	Saddles that are not clamped, but are designed to pivot in a vertical plane with respect to the seat-post, shall be allowed to move within the parameters of the design and shall withstand the tests described in 4.3.15.3.4 without failure of any components.	No any failure found after the test	P

Table 31 — Forces on saddle

Vertical force, F_{18}	650
Horizontal force, F_{19}	250

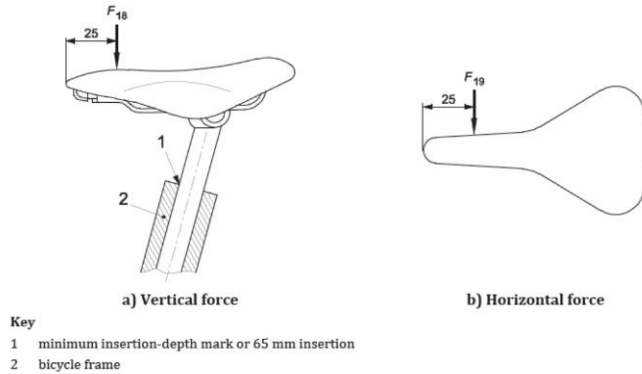


Figure 48 — Saddle/seat-post: safety test

4.3.15.4

Saddle – Static strength test

P

4.3.15.4.1

Requirement

P

When tested by the method described in 4.3.15.4.2, the saddle cover and/or plastic moulding shall not disengage from the chassis of the saddle, and there shall be no cracking or permanent distortion of the saddle assembly.

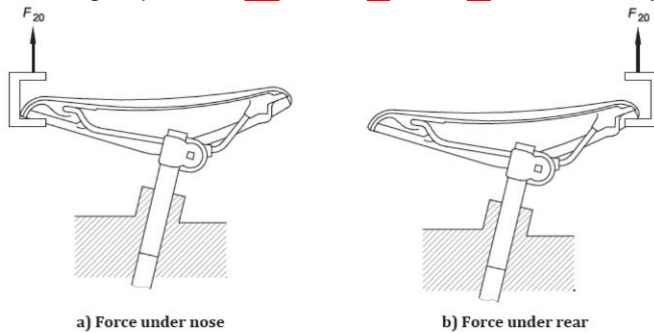
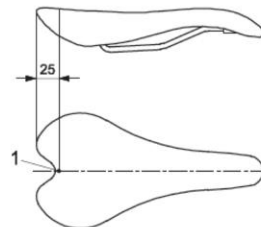


Figure 49 — Saddle: static strength test



Key
1 loading point

Figure 50 — Saddle: load application point of static strength test

No cracking or permanent distortion found after the test

P

4.3.15.5

Saddle and seat-post clamp – Fatigue test

P

4.3.15.5.1

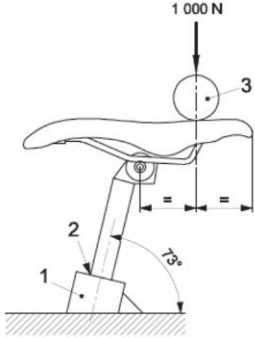
General

P

Seat-posts can influence test failures of saddles: for this reason, a saddle shall be tested in combination with a

P



	seat-post as recommended by the saddle manufacturer.		
4.3.15.5.2	Requirement		P
	<p>When tested by method described in 4.3.15.5.3, there shall be no fractures or visible cracks in the seat-post or in the saddle, and no loosening of the clamp.</p>  <p>Key 1 rigid mount 2 minimum insertion-depth mark 3 pad (length = 300 mm, diameter = 80 mm)</p> <p>Figure 51 — Saddle and seat-post clamp fatigue test</p>	No fractures or visible cracks found after the test	P
4.3.15.6	Seat-post – Fatigue test	No suspension seat-post	P
4.3.15.6.1	General		P
	In the following test, if a suspension seat-post is involved, the test shall be conducted with the suspension system adjusted to give maximum resistance.		P
	Conduct the test in two stages on the same assembly as per 4.3.15.6.2 and 4.3.15.6.4.		P
4.3.15.6.2	Requirement for stage 1		P
4.3.15.6.2.1	Seat-post without suspension system		P
	When tested by the method described in 4.3.15.6.3, there shall be no visible cracks or fractures in the seat-post, nor any bolt failure.		P
	For composite seat-post, the peak deflection of seat-post during the test shall not increase by more than 20 % of the initial value.		P
4.3.15.6.2.2	Seat-post with suspension system		P
	When tested by the method described in 4.3.15.6.3, there shall be no visible cracks or fractures in the seat-post, nor any bolt failure. The design shall be such that in the event of failure of the suspension system, the two main parts do not separate nor does the upper part (i.e. the part to which the saddle would be attached) become free to swivel in the lower part.		P

	<p align="center">Table 32 — Forces on seat-post</p> <table border="1"> <tr> <td>Bicycle type</td> <td></td> </tr> <tr> <td>Force, F_{21}</td> <td>1 000</td> </tr> </table> <p>Key 1 minimum insertion-depth mark 2 repeated test force</p> <p align="center">Figure 52 — Seat-post: fatigue test</p>	Bicycle type		Force, F_{21}	1 000		
Bicycle type							
Force, F_{21}	1 000						
4.3.15.6.4	Requirement for stage 2		P				
4.3.15.6.4.1	Seat-post without suspension system		P				
	When tested by the method described in 4.3.15.6.5, there shall be no fractures, and the displacement shall not exceed 10 mm during testing.		P				
4.3.15.6.4.2	Seat-post with suspension system		P				
	When tested by the method described in 4.3.15.6.5, there shall be no fractures. The design shall be such that in the event of failure of the suspension system, the two main parts do not separate nor does the upper part (i.e. the part to which the saddle would be attached) become free to swivel in the lower part.		P				
	<p align="center">Table 33 — Forces on seat-post</p> <table border="1"> <tr> <td>Force, F_{22}</td> <td>2 000</td> </tr> </table> <p>Key 1 minimum insertion-depth mark</p> <p align="center">Figure 53 — Seat-post: static strength test</p>	Force, F_{22}	2 000				
Force, F_{22}	2 000						
4.3.16	Spoke protector		P				
	EPAC bicycles with multiple free-wheel/cassette sprockets shall be fitted with a spoke-protector guard to prevent the chain interfering with or stopping rotation of the wheel through improper adjustment or damage.	Spoke protector fitted	P				
4.3.17	Luggage carriers	No luggage carriers	N				



	If luggage carriers are fitted or provided they shall comply with EN ISO 11243.		N
4.3.18	Road-test of a fully-assembled EPAC		P
4.3.18.1	Requirements		P
	When tested by the method described in 4.3.18.2, there shall be no system or component failure and no loosening or misalignment of the saddle, handlebar, controls or reflectors.	No system or component failure found after the test No loosening or misalignment found after the test	P
	The EPAC shall with or without assistance exhibit stable handling in braking, turning and steering, and it shall be possible to ride with one hand removed from the handlebar (as when giving hand signals), without difficulty of operation or hazard to the rider.		P
4.3.19	Lighting systems and reflectors		P
4.3.19.1	General		P
	EPAC shall be equipped with reflectors at the front, rear and side. EPAC shall be equipped with lighting systems and reflectors in conformity with the national regulations in the country in which EPAC is marketed, because national regulations for lighting systems and reflectors differ from country to country.		P
4.3.19.2	Wiring harness		P
	When a wiring harness is fitted, it shall be positioned to avoid any damage by contact with moving parts or sharp edges. All connections shall withstand a tensile force in any direction of 10 N.	No damage found after the test	P
4.3.19.3	Lighting systems		P
	The lighting system consists of a front and a rear light. These devices shall comply with the provisions in force in the country in which the product is marketed. If there are no forced provisions of these devices, the lighting system shall comply with the requirements of ISO 6742-1.	ISO 6742-1 complied	P
4.3.19.4	Reflectors		P
4.3.19.4.1	General		P
	These devices shall comply with the provisions in force in the country in which the product is marketed. If there are no forced provisions of these devices, the retro-reflective devices shall comply with the requirements of ISO 6742-2.	ISO 6742-2 complied	P
4.3.19.4.2	Rear reflectors		P
	Rear reflectors shall be red in colour.	Color: red	P
4.3.19.4.3	Side reflectors		P
	The retro reflective device(s) shall be either a) a reflectors fitted on the front half and on the rear half of EPAC. At least one of these shall be mounted on the spokes of the wheel. Where EPAC incorporates features at the rear wheel other than the frame and mudguard stays, the moving reflector shall be mounted on the front		P



	wheel; or b) a continuous circle of reflective material applied to both sides of each wheel within 10 cm of the outer diameter of the tyre.										
	All side reflectors shall be of the same colour, either white (clear) or yellow.		P								
4.3.19.4.4	Front reflectors		P								
	Front reflectors shall be white (clear) in colour.	Color: white	P								
4.3.19.4.5	Pedal reflectors		P								
	Each pedal shall have reflectors, located on the front and rear surfaces of the pedal. The reflector elements shall be either integral with the construction of the pedal or mechanically attached, but shall be recessed from the edge of the pedal, or of the reflector housing, to prevent contact of the reflector element with a flat edge placed in contact with the edge of the pedal.		P								
4.3.20	Warning device		P								
	Where a bell or other suitable device is fitted, it shall comply with the provisions in force in the country in which the product is marketed.		P								
4.3.21	Thermal hazards		P								
	A warning shall be placed on the surface if the temperature of the hot accessible surface could be above 60 °C (see EN ISO 7010:2012, symbol W017). Brake systems are excluded from this requirement.	No such hazards	P								
4.3.22	Performance levels (PLrs) for control system of EPACs		P								
	The safety related parts of the control systems of the EPAC shall comply with the required performance level (PLr) given in Table 34 in accordance with EN ISO 13849-1.	EN ISO 13849-1 complied	P								
	Should risk assessment indicate that additional or different PLr are required for a particular application, these should be determined in accordance with EN ISO 13849 (all parts). Such PLr will be outside the scope of this standard.		P								
	The manufacturer of the EPAC shall record the process adopted for verification of compliance with PLr for each relevant safety function. <table border="1" style="margin-left: auto; margin-right: auto;"> <caption>Table 34 — Safety functions related to defined hazards</caption> <thead> <tr> <th>Safety function</th> <th>Performance Level</th> </tr> </thead> <tbody> <tr> <td>Prevention of an unintentional self-start of the EPAC</td> <td>PLr c</td> </tr> <tr> <td>Prevention of electric motor assistance functions without pedalling, and without activation of the start-up assistance mode</td> <td>PLr c</td> </tr> <tr> <td>Prevention of risk of fire in case of management system failure for batteries with capacity above 100 Wh</td> <td>PLr c</td> </tr> </tbody> </table>	Safety function	Performance Level	Prevention of an unintentional self-start of the EPAC	PLr c	Prevention of electric motor assistance functions without pedalling, and without activation of the start-up assistance mode	PLr c	Prevention of risk of fire in case of management system failure for batteries with capacity above 100 Wh	PLr c		P
Safety function	Performance Level										
Prevention of an unintentional self-start of the EPAC	PLr c										
Prevention of electric motor assistance functions without pedalling, and without activation of the start-up assistance mode	PLr c										
Prevention of risk of fire in case of management system failure for batteries with capacity above 100 Wh	PLr c										
4.4	List of significant hazards		P								
	The following significant hazards have been considered in this standard:	No listed hazards	P								
	a) Mechanical hazards: high deceleration, high acceleration, Protrusion, instability; kinetic energy; rotating elements and moving elements, rough, slippery surface, sharp edges; b) Electrical hazards: electromagnetic phenomena; electrostatic phenomena; overload; short-circuit; thermal radiation;		P								



	<p>c) Thermal hazards: explosion; flame; radiation from heat sources;</p> <p>d) Ergonomic hazards: effort; lighting; posture;</p> <p>e) Hazards associated with the environment in which the machine is used: water (rain and projection);</p> <p>f) Combination of hazards: braking under wet and dry condition, handgrips, motor management system, engine power management, installed braking power.</p>		
5.	Marking, labelling		P
5.1	Requirement		P
	<p>The EPAC shall be marked visibly, legibly and indelibly with the following minimum particulars:</p> <ul style="list-style-type: none"> — contact and address of the manufacturer or authorized representative; — EPAC according to EN 15194; — appropriate marking required by legislation (CE); — year of construction, that is the year in which the manufacturing was completed (it is not possible to use a code); — cut off speed XX km/h; — maximum continuous rated power XX kW; — maximum permissible total weight (e.g. marked near the seat post or handlebar); — designation of series or type; — individual serial number if any; — mass if EPAC mass is more than 25 kg; — mass of the EPAC in the most usual configuration. 		P
	<p>The frame shall be:</p> <p>a) visibly and permanently marked with a successive frame number at a readily visible location such as near the pedal-crank, the seat-post, or the handlebar;</p> <p>b) visibly and durably marked, with the name of the manufacturer of complete EPAC or the manufacturer's representative and the number of this document, i.e. EN 15194.; the method of testing for durability is specified in 5.2.</p>		P
	<p>Where appropriate, if EPAC is equipped with a coupling device for a trailer the following values shall be given:</p> <p>c) total weight of the trailer;</p> <p>d) vertical load on the coupling system.</p>		P
	<p>For components, currently there are no specific requirements, but it is recommended that the following safety critical components be clearly and permanently marked with traceable identification, such as a manufacturer's name and a part number:</p> <ul style="list-style-type: none"> e) front fork; f) handlebar and handlebar-stem; g) seat-post; h) brake-levers, brake blocks and/or brake-block holders; i) outer brake-cable casing; j) hydraulic-brake tubing; k) disc-brake callipers, brake-discs, and brake pads; l) chain; m) pedals and cranks; n) bottom-bracket spindle; 		P



	o) wheel-rims.		
5.2	Durability test		P
5.2.1	Requirement		P
	When tested by the method described in 5.2.2, the marking shall remain easily legible. It shall not be easily possible to remove any label nor shall any label show any sign of curling.		P
5.2.2	Test method		P
	Rub the marking by hand for 15 s with a piece of cloth soaked in water and again for 15 s with a piece of cloth soaked in petroleum spirit.		P
6	Instruction for use		P
	<p>Each EPAC shall be provided with a set of instructions in the language of the country to which EPAC will be supplied. Different countries may have local requirements regarding this type of information (see EN 82079-1). Instructions for use shall be delivered obligatory in paper form. For more detailed information and enabling an access for vulnerable people instructions for use should be available additionally in electronic form on demand. Instructions for use shall contain the following information on:</p> <ul style="list-style-type: none"> a) Concept and description of electric assistance including varying levels of motor assistance; b) Recommendation for cleaning and the use of high pressure cleaners; c) Control and tell tales; d) Specific EPAC recommendation for use (e.g. removal of the battery, temperature range for the use of the bicycle including battery, use of start-up assistance mode); e) Specific EPAC warnings (e.g. always remove the battery during maintenance, inappropriate use including manipulation of the electric management system); f) Recommendations about battery charging and charger use (e.g. temperature range for the battery storage, indoor or outdoor charging) as well as the importance of following the instruction contained on the label of the battery charger; g) The meaning of symbol and tell tales used shall be explained in the instruction for use. Warning about contact with hot surfaces as for example disc brakes after heavy use; h) The type of use for which EPAC has been designed (i.e. the type of terrain for which it is suitable) with a warning about the hazards of incorrect use; i) Preparation for riding - how to measure and adjust the saddle height to suit the rider with an explanation of the insertion-depth warning marks on the seat-post and handlebar-stem. Clear information on which lever operates the front brake, which lever operates the rear brake, the presence of any brake-power modulators with an explanation of their function and adjustment, and the correct method of using a back-pedal brake if fitted; 		P



	<p>j) Indication of minimum saddle height and the way to measure it;</p> <p>k) The recommended method for adjusting any adjustable suspension system fitted;</p> <p>l) Recommendations for safe riding, the use of a bicycle helmet, regular checks on brakes, tyre pressure, steering, rims and caution concerning possible increased braking distances in wet weather;</p> <p>m) The safe use and adjustment of foot-securing devices if fitted (i.e. quick-release pedals and toe-clips);</p> <p>n) The permissible total payload (rider plus luggage) and the empty weight of the EPAC;</p> <p>o) Recommendation about usage for bicycle trailer or trailer bicycle if allowed by EPAC manufacturer;</p> <p>p) An advisory note to draw attention to the rider concerning possible national legal requirements when EPAC is to be ridden on public roads (e.g. lighting and reflectors);</p> <p>q) Recommended tightening of fasteners related to the handlebar, handlebar-stem, saddle, seat-post, wheels, and aerodynamic extension if fitted with torque values for threaded fasteners;</p> <p>r) The method for determining the correct adjustment of quick-release devices, such as “the mechanism should emboss the fork-ends when closed to the locked position”;</p> <p>s) The correct method of assembling any parts supplied unassembled;</p> <p>t) Lubrication - where and how often to lubricate, and the recommended lubricants;</p> <p>u) The correct chain tension and how to adjust it (if appropriate);</p> <p>v) Adjustments of gears and their operation (if appropriate);</p> <p>w) Adjustment of brakes and recommendations for the replacement of the friction components;</p> <p>x) Recommendations on general maintenance;</p> <p>y) The importance of using only genuine replacement parts for safety-critical components;</p> <p>z) Care of the wheel-rims and a clear explanation of any danger of rim-wear (see also 4.3.10.4 and 5.1):</p>		
	<p>For composite rims wear damage may be invisible to the user, the manufacturer shall explain the consequences of rim wear and how the cyclist can assess the degree of wear or should recommend returning the composite rim to the manufacturer for inspection.</p>		P
	<p>aa) The correct gluing technique for wheels equipped with tubular tyres if fitted;</p> <p>bb) Appropriate spares, i.e. tyres, tubes, and brake friction-components;</p> <p>cc) Accessories - where these are offered as fitted, details should be included such as operation, maintenance required (if any) and any relevant spares (e.g. light bulbs);</p> <p>dd) An advisory note to draw attention of the rider to possible damage due to intensive use and to recommend periodic inspections of the frame, fork,</p>		P



	<p>suspensions joints (if any), and composite components (if any). The wording of the advice may be as follows; WARNING 1 — As with all mechanical components, EPAC is subjected to wear and high stresses. Different materials and components may react to wear or stress fatigue in different ways. If the design life of a component has been exceeded, it may suddenly fail, possibly causing injuries to the rider. Any form of crack, scratches or change of colouring in highly stressed areas indicate that the life of the component has been reached and it should be replaced. WARNING 2 — For composite components impact damage may be invisible to the user, the manufacturer shall explain the consequences of impact damage and that in the event of an impact; composite components should either be returned to the manufacturer for inspection or destroyed and replaced. ee) For composite components, an advisory note to draw attention to the influence of high temperature (heat radiations) in confined environment on composite materials (if appropriate); ff) importance of possibly suitably covering any coil springs under the saddle if a child-seat is fitted to prevent trapping of fingers; gg) The handlebar, the rider's response to steering and braking can be adversely affected; hh) The maximum inflation pressure for a conventional or tubular tyre, according to the lowest value between maximum inflation pressure recommended on the rim or the tyre (see also 4.3.10.2); ii) Recommendation on the installation of bicycle carriers as well as child seats (max. load, mounting, etc.): It is permitted to include any other relevant information at the discretion of the manufacturer jj) Definition of tampering in user manual (i.e. exclude exchange of sprocket with non-original parts); kk) Recommendations and users responsibility in case of tampering; ll) The following statement: The A-weighted emission sound pressure level at the driver ears is less than 70 dB(A).</p>		
--	---	--	--



4.1		EN ISO 12100 safety requirements and evaluation			P
No	Type or group	Origin	Potential consequences	Subclause of this International	Evaluation
1	Mechanical hazards	<ul style="list-style-type: none"> - acceleration, deceleration; - angular parts; - approach of a moving element to a fixed part; - cutting parts; - elastic elements; - falling objects; - gravity; - height from the ground; - high pressure; - instability; - kinetic energy; - machinery mobility; - moving elements; - rotating elements; - rough, slippery surface; - sharp edges; 	<ul style="list-style-type: none"> - being run over; - being thrown; - crushing; - cutting or severing; - drawing - in or trapping; - entanglement; - friction or abrasion; - impact; - injection; - shearing; - slipping, tripping and falling; - stabbing or puncture; - suffocation. 	<ul style="list-style-type: none"> 6.2.2.1 6.2.2.2 6.2.3 a) 6.2.3 b) 6.2.6 6.2.10 6.3.1 6.3.2 6.3.3 6.3.5.2 6.3.5.4 6.3.5.5 6.3.5.6 6.4.1 6.4.3 6.4.4 6.4.5 	No such hazards
2	Electrical hazards	<ul style="list-style-type: none"> - arc; - electromagnetic phenomena; - electrostatic phenomena; - live parts; - not enough distance to live parts under high voltage; - overload; - parts which have become live under fault conditions; - short - circuit; 	<ul style="list-style-type: none"> - burn; - chemical effects; - effects on medical implants; - electrocution; - falling, being thrown; - fire; - projection of molten particles; - shock. 	<ul style="list-style-type: none"> 6.2.9 6.3.2 6.3.3.2 6.3.5.4 6.4.4 6.4.5 	N/A
3	Thermal hazards	<ul style="list-style-type: none"> - explosion; - flame; - objects or materials with a high or low temperature; - radiation from heat sources. 	<ul style="list-style-type: none"> - burn; - dehydration; - discomfort; - frostbite; - injuries by the radiation of heat sources; 	<ul style="list-style-type: none"> 6.2.4 b) 6.2.8 c) 6.3.2.7 6.3.3.2.1 6.3.4.5 	N/A
4	Noise hazards	<ul style="list-style-type: none"> - cavitation phenomena; - exhausting system; - gas leaking at high speed; - manufacturing process (stamping, cutting, etc.); - moving parts; - scraping surfaces; - unbalanced rotating parts; - whistling pneumatics; - worn parts. 	<ul style="list-style-type: none"> - discomfort; - loss of awareness; - loss of balance; - permanent hearing loss; - stress; - tinnitus; - tiredness; - any other (for example, mechanical, electrical) as a consequence of an interference with speech 	<ul style="list-style-type: none"> 6.2.2.2 6.2.3 c) 6.2.4 c) 6.2.8 c) 6.3.1 6.3.2.1 b) 6.3.2.5.1 6.3.3.2.1 6.3.4.2 6.4.3 6.4.5.1 b) and c) 	N/A



5	Vibration hazards	<ul style="list-style-type: none"> - cavitation phenomena; - misalignment of moving parts; - mobile equipment; - scraping surfaces; - unbalanced rotating parts; - vibrating equipment; - worn parts. 	<ul style="list-style-type: none"> - discomfort; - low - back morbidity; - neurological disorder; - osteo - articular disorder; - trauma of the spine; - vascular disorder. 	<p>6.2.2.2 6.2.3 c) 6.2.8 c) 6.3.3.2.1 6.3.4.3 6.4.5.1 c)</p>	N/A
6	Radiation hazards	<ul style="list-style-type: none"> - ionizing radiation source; - low frequency electromagnetic radiation; - optical radiation ĩ, infrared, visible and ultravioletĳ , including laser; - radio frequency 	<ul style="list-style-type: none"> - burn; - damage to eyes and skin; - effects on reproductive capability; - mutation; 	<p>6.2.2.2 6.2.3 c) 6.3.3.2.1 6.3.4.5 6.4.5.1 c)</p>	N/A
7	Material/ substance hazards	<ul style="list-style-type: none"> - aerosol; - biological and microbiological ĩ, viral or bacterialĳ agent; - combustible; - dust; - explosive; - fibre; - flammable; 	<ul style="list-style-type: none"> - breathing difficulties, suffocation; - cancer; - corrosion; - effects on reproductive capability; 	<p>6.2.2.2 6.2.3 b) 6.2.3 c) 6.2.4 a) 6.2.4 b) 6.3.1 6.3.3.2.1 6.3.4.4</p>	No such hazards
8	Ergonomic hazards	<ul style="list-style-type: none"> - access; - design or location of indicators and visual displays units; - design, location or identification of control devices; - effort; - flicker, dazzling, shadow, stroboscopic effect; - local lighting; - mental overload/underload; - posture; 	<ul style="list-style-type: none"> - discomfort; - fatigue; - musculoskeletal disorder; - stress; - any other ĩ, for example, mechanical, electricalĳ as a consequence of a human error. 	<p>6.2.2.1 6.2.7 6.2.8 6.2.11.8 6.3.2.1 6.3.3.2.1</p>	N/A
9	Hazards Associated with the environment in which the machine is used	<ul style="list-style-type: none"> - dust and fog; - electromagnetic disturbance; - lightning; - moisture; - pollution; - snow; - temperature; - water; - wind; - lack of oxygen. 	<ul style="list-style-type: none"> - burn; - slight disease; - slipping, falling; - suffocation; - any other as a consequence of the effect caused by the sources of the hazards on the machine or parts of the machine. 	<p>6.2.6 6.2.11.11 6.3.2.1 6.4.5.1 b)</p>	N/A
10	Combination of hazards	- for example, repetitive activity + effort + high environmental temperature	- for example, dehydration, loss of awareness, heat stroke	—	N/A



4.2A	TABLE:temperature rise measurements					P
	t1(°C)	24.2			-	
	t2(°C)	24.5			-	
	Test Voltage(V)	54.6VDC			-	
	Input current for DC motor(A)	2.0A			-	
	Rated continuous Power on shaft	106.4W			-	
	Winding temperature rise measurements:				P	
	Insulation calss	See below			-	
Temperature rise dT of winding	R ₁ (Ω)	R ₂ (Ω)	dT(k)	Required dT(K)	Insulation class	
DC Motor Winding	--	--	65.2	95	B	
Temperature rise measurements					P	
	t ₁ (°C)	24.2				
	t ₂ (°C)	24.5				
Temperature rise dT part/at:	t _m °C	T _c °C		Required T _{max} °C		
Enclosure of battery unit -1	38.7	56.0		70		
Enclosure of batter unit -3	39.3	56.6		70		
Plastic enclosure of battery compartment inside	37.4	51.8		70		
Appliance inlet connector	36.7	53.6		85		
Fuse holder	44.2	60.8		85		
DC connector	48.4	64.9		85		
NOTE: t _m =measured temperature e t _c =t _m corrected (t _m -t _c +40°C max. RATED ambient) t _{max} =maximum permitted temperature						

4.2B	TABLE:Fault condition tests				P
	Ambient temperature(°C)		22.0	-	
Fault No.	Fault	Supply voltage(V)	Test time	Observation	
4.2.2-1)	Battery terminal S-C	54.6VDC	1s	Output voltage from 54.6V in normal condition decrease to 0V when terminal s-c, fuse broken, battery recoverable after new fuse replaced. No hazard occur, no obvious temperature rise, no flame, molten metal or poisonous gas appear.	
4.2.2-2)	Motor input(controller output) two terminals s-c	54.6VDC	10min	EPAC system stop, normal current of battery decrease from 2.0A to 0.04A, output of controller decrease to 0A when drive motor locked. No hazard occur, no obvious temperature rise, no flame,	



				molten metal or poisonous gas appear.
4.2.2-2)	Motor input(controller output) all three terminals s-c	54.6VDC	1h	Normal current of battery decrease from 2.0A to 1.2A, output of controller s-c, mosfet in controller in overload condition and broken after 15min, excess temperature observed in aluminium case of controller. No flame, molten metal or poisonous gas appear. Controller not recoverable.
4.2.2-3)	Motor block	54.6VDC	10min	EPAC system stop, normal current of battery decrease from 2.0A to 0.07A, output of controller decrease to 0A when drive motor locked. No hazard occur, no obvious temperature rise no flame, molten metal or poisonous gas appear.
4.2.2-4)	Battery over charging	54.6VDC	2 times charging period or 2h	Battery charger turns from red to green after 2hours charging, no hazard occur, no obvious temperature rise, no flame, molten metal of poisonous gas appear 24 hours overcharging.

Supplementary information:

Note 1:Normal charging time for the battery charger is 4 hours, so test for 4.2.2-4) is 24 hours.

4.2.3	TABLE:Batteries			P
Is it possible to install the battery in a reverse polarity position?		No	P	
Rechargeable batteries				
		Charging		discharging
	Meas. current	Manuf. Specs.	Meas. current	Manuf. Specs.
Max. current during normal condition	1.94	15A	9.54A	15A
Testresults				Verdict
- Chemical leaks				
- Explosion of the battery				
- Emission of flame or expulsion of molten metal				
- Electric strength tests of equipment after completion of tests				
Supplementary information:				
1. Charging current measured at AC 240V, 50Hz input of battery charger.				
2. Discharging current measured at battery terminal with EPAC in normal ride condition average speed 20km/h. Start current of battery is about 15.0A for 2-3 seconds.				



4.2.6	TABLE:Electric strength tests for wiring		P
Test voltage applied between:		Voltage shape (AC, DC impulse, surge)	Test Voltage (V)
Input terminal of controller – metal frame		DC	609.2V
Supplementary information:500+2XVr for 2min, Vr is the rated voltage			

4.2.13	TABLE:Power Management		P
Test condition:Worst condition of the lowest gear ratio and 90% cut off speed as below, brake lever cut off switch for front wheel operate. Limit distance for this condition is 5 meters.			
t1=0.424s	S1=Vavr X t1=3.125X0.423s=1.34m		
T2=0.428s	S2=Vavr X t2=3.125X0.425s=1.34m		
T3=0.396s	S3=Vavr X t3=3.125X0.386s=1.25m		
T4=0.462s	S4=Vavr X t4=3.125X0.472s=1.44m		
T5=0.420s	S5=Vavr X t5=3.125X0.428s=1.35m		
T6=0.408s	S6=Vavr X t6=3.125X0.410s=1.29m		
T7=0.396s	S7=Vavr X t7=3.125X0.396s=1.26m		
T8=0.410s	S8=Vavr X t8=3.125X0.422s=1.28m		
T9=0.422s	S9=Vavr X t9=3.125X0.447s=1.32m		
t10=0.426s	S10=Vavr X t10=3.125X0.436s=1.33m		
Savr=(s1+S2+...+S9+s10)/10=1.32m			
NOTE: Vstart:Start speed of front wheel which is 90% cut off speed. Vend:End speed of front wheel after brake lever cut off switch. Vavr:Average speed of front wheel from start to end. tn:Time between actuating the switch brake to no load current point monitored in current meter. Sn:Cut off distance in one measure, savr:average Cut Off distance in 10 times.			



Measurement and Test Equipment List		
Description	MTE Type/model Internal ID	Next Calibration
Multimeter	15B/E016	2026-05-31
Digital Power Meter	WT210/E022	2026-05-27
Voltage withstand tester	TOS5101/E035	2026-05-06
Digital oscillograph	DL1620/E037	2026-03-01
Test Finger	9101/L001	2026-03-04
Vernier	125mm/L004	2026-03-01
Temperature recorder	MV2048/T007	2026-03-14
Isolated Transformer	BK-500VA/Z001	-
NF Power supply	EPO2000S/Z018	-
Motor load tester	-/S86	2026-06-30
Speed/time/distance meter	-/Y176	2026-03-17
IPx3,4 tester	Z015/1092	2026-04-16
AC/DC clamp meter	M240/H80151	2026-03-14

Remarks: P-Pass; N/A – Not Applicable

DRAFT



EUT Photo

Photo 1



Photo 2





Photo 3



Photo 4





Photo 5



Photo 6



Photo 7



Photo 8

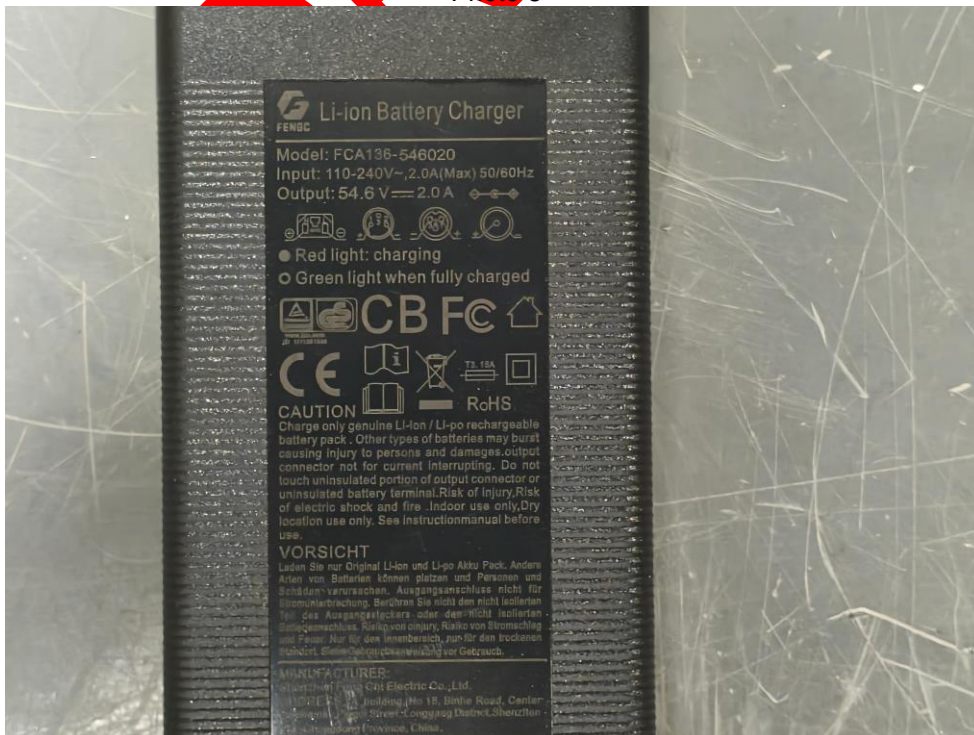




Photo 9



***** END OF REPORT *****

DRY